



# FILL THE GAP – JOIN THE JAP

JOINT ACTION PROJECT 2020 IN PORT ELIZABETH, SOUTH AFRICA



# FILL THE GAP – JOIN THE JAP

DOCUMENTATION  
EXCHANGE PROGRAMME SEPT 2019 – FEB 2020  
JAP (JOINT ACTION PROJECT) FEB 2020  
MARA BIEBOW, ALENA ENGEL, JANA MEIER, UTA SCHEIBE

# TABLE OF CONTENTS

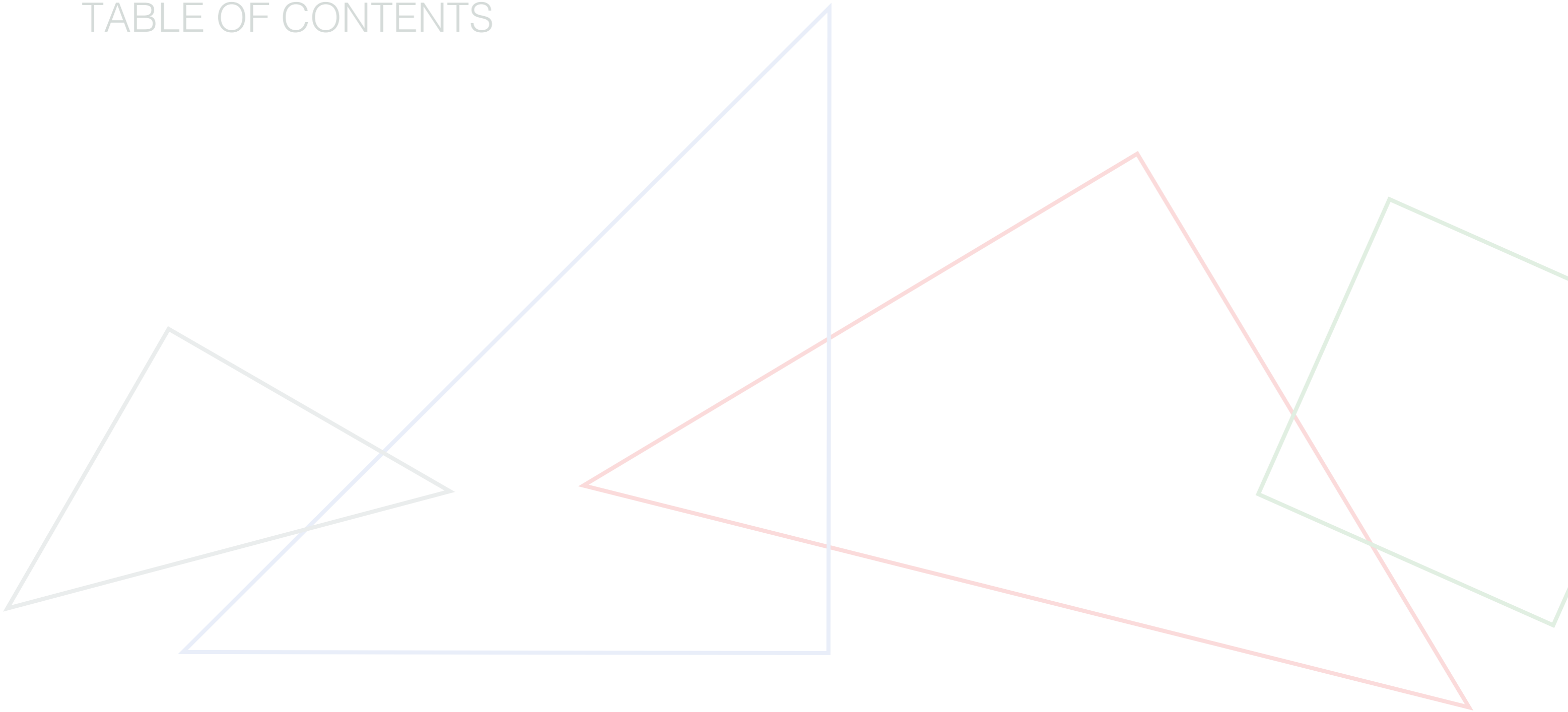

## INTRODUCTION

I.I	Join the JAP	05
I.II	Behind the Logo	06
I.III	Academic Basis	08

## DOCUMENTATION

II.I	Introduction and Impressions	11
II.II	History of Walmer Township	13
II.III	Key Data and Basic Information	17
II.IV	Infrastructure and Services	19
II.V	Diversity of the Settlement	21

## SITE ANALYSIS

III.I	Introduction and Impressions	26
III.II	Mission of the Project	28
III.III	Natural Factors	30
III.IV	Surroundings	32
III.V	Khusta's Home	34

## PREPARATION

IV.I	Introduction and Impressions	39
IV.II	The First Steps	41
IV.III	Places of Interests	43
IV.IV	Workshops	45
IV.V	Building Material	47
IV.VI	The Cart Project	51

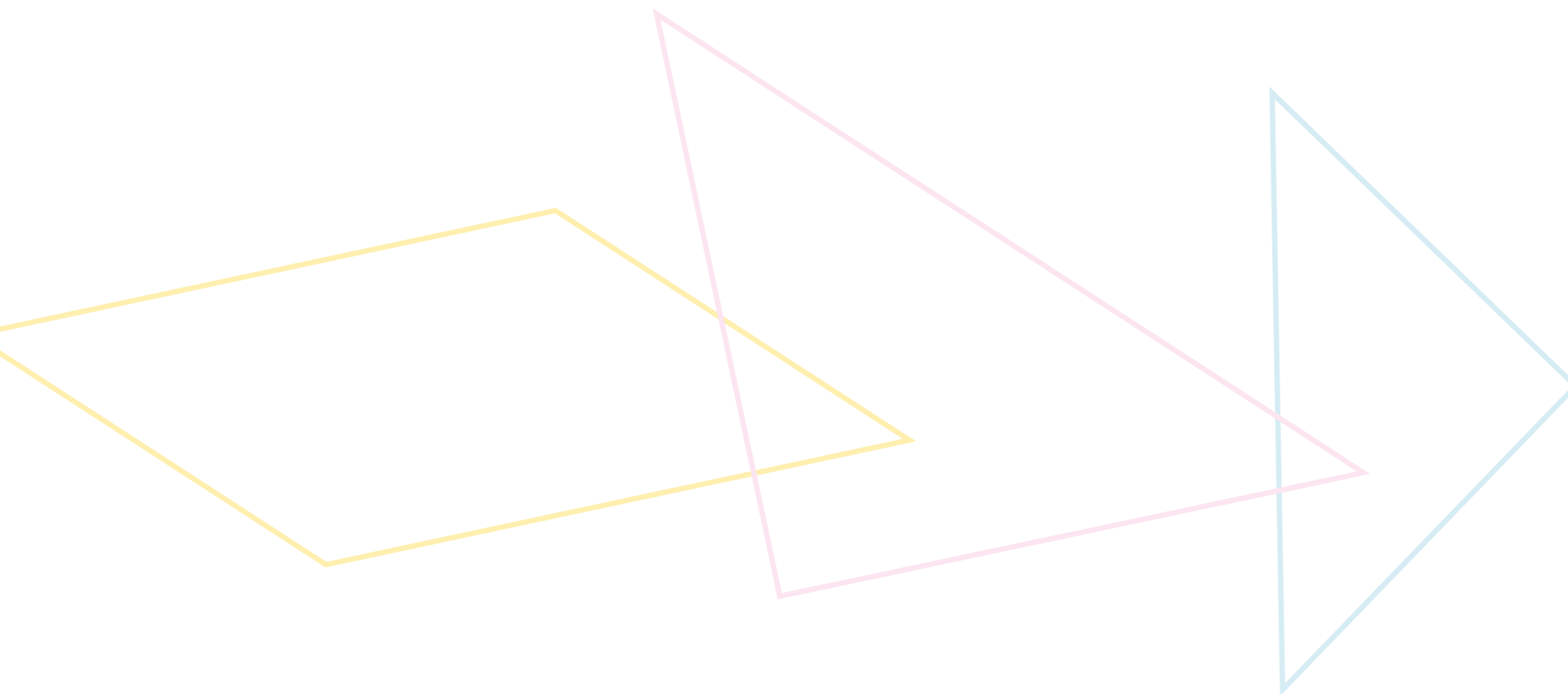

## CONCEPT

V.I	Introduction and Impressions	54
V.II	Participatory Design Process	56
V.III	Group Concepts and Profiles	58
V.IV	The Strongest Points Combined	66

## DESIGN

VI.I	Introduction and Impressions	69
VI.II	Building in Phases	71
VI.III	Site Plan	73
VI.V	Drawings for Execution	75

## IMPLEMENTATION

VII.I	Introduction and Impressions	82
VII.II	The Construction Team	84
VII.III	Tasks and Pre-Fabrication	86
VII.IV	Assembly	90
VII.V	The Final Structure	92
VII.VI	Postscript	96

## APPENDIX

A.	Team Members and Supporters	98
B.	Sources and References	99
C.	Partners and Sponsors	100
D.	Contributors	102





# INTRODUCTION

FOREWORD – ACADEMICS – LOGO



# INTRODUCTION

## I.1 JOIN THE JAP

Dear Reader,

some people refer to us as «guinea pigs», we prefer to call ourselves «pioneers». Pioneers of a student exchange that has never been done like this before. Pioneers of a project that ought to make a sustainable difference to the living circumstances of people. Pioneers who are from different fields, different backgrounds and different countries. Pioneers who want to fill the gap that is entrusted to them. Ten students are forming our group of pioneers: four students from Wismar University of Applied Science (GER), four students from Nelson Mandela University, Port Elizabeth (SA) and two students from Port Elizabeth TVET College (SA). Our academical backgrounds range from architecture and civil engineering via communication design, development studies and electrical engineering to human settlements. Combining our broadly-based knowledge we are working towards the defined goal of implementing a sustainable structure in Walmer Township, Port Elizabeth, to support one of its residents in setting up a business.

To gain a deeper insight and understanding of townships, development and participatory design we took part in a tailor-made Short Learning Programme at Nelson Mandela University. This international, cross-disciplinary, and participatory setup of the project is unique amongst the exchange opportunities offered at Wismar University as well as amongst the academic exchange programmes at Nelson Mandela University and PE College. It is enabled through the German Academic Exchange Service (DAAD) as part of a funding programme called «Subject-specific Partnerships with Universities in Developing Countries», with funds of the German Federal Ministry of Economic Cooperation and Development (BMZ).

Also part of the exchange is the long-established collaboration with a Port Elizabeth-based architect who assisted in the participatory design process of the soon-to-be-built structure, that will be set up not just by our team of pioneers, but also by a team of students from Wismar. This team was in close collaboration with our side through the duration of the design and preparation phase by taking over specific design tasks as well as technical drawings within their research module. By the end of February 2020 the collectively designed structure ought to be implemented with their assistance. Following the intense five months in South Africa, the German students will be hosting our South African fellow students in June for workshops related to our subject and joint field trips.

As the first group within a three-year-project we are exploring possibilities, dealing with organisational challenges and finding solutions for them. The book in your hands will show you our exploration, our tasks and the challenges that occurred. It serves as an overview, report, documentation, manual for the next group and resumé at once.

The Joint Action Project 2019/20 will pave the path for the following two years. It will not end with the implementation of the structure in 2020, ensuring not just the sustainability of the structure itself but also of the cooperation between Wismar University, Nelson Mandela University and TVET College. It also offers the chance to create a lasting bond between students across borders and countries, who are keen to make a difference and change the world together.

*The Pioneers*

# INTRODUCTION

## I.II BEHIND THE LOGO

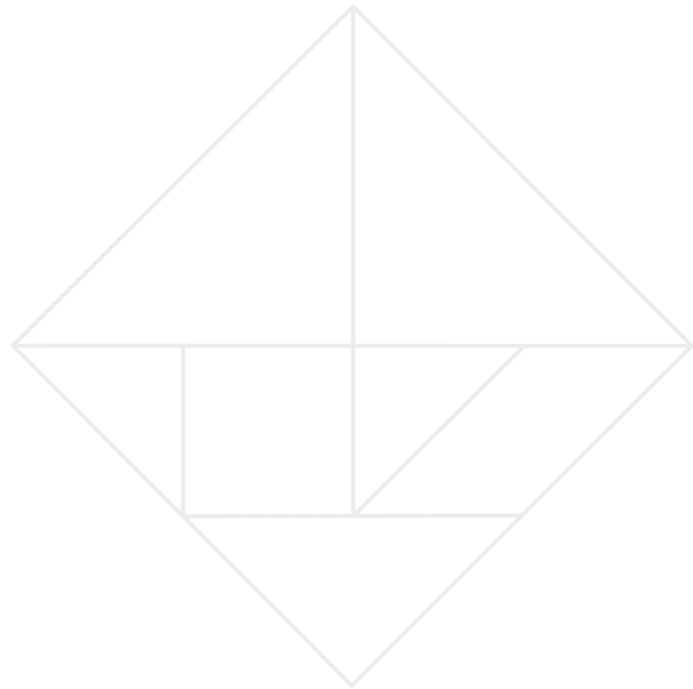

## THE IDEA

### PIECES OF A PUZZLE

The image of a puzzle occurred early in the process when we realized how many people are part of the project, how different the approaches are and how many small tasks contribute to the final building project. But a puzzle is terminated and there is only one solution for it, one final image. Our Joint Action Project (JAP) is neither terminated nor is there a one-and-only solution. Our puzzle pieces can be arranged in multiple ways, the outcome is not set from the beginning and you can continue arranging them endlessly until you agree on one outcome.

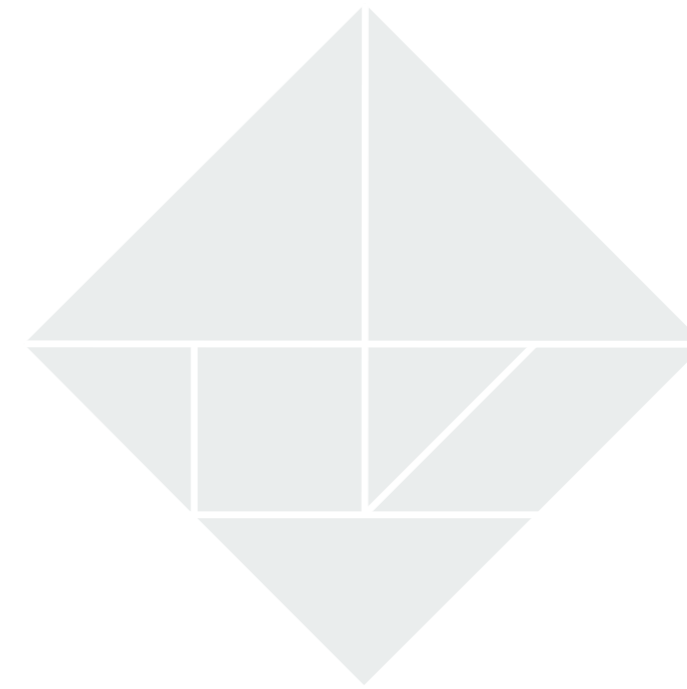

## THE TANGRAM

### A PUZZLE WITH A MILLION OUTCOMES

Unlike common jigsaw puzzles, the tangram offers an incredibly wide range of potential outcomes. And the number is still growing. The origin of the tangram is unclear, though tile-based games like this date back as far as the third century B.C.

The original tangram consists of seven pieces: two large triangles, two small triangles, one medium-size triangle, one square and one parallelogram. The basic shape is a square. Out of the seven pieces you have to assemble a given shape or silhouette (called «problem»).

With the seven different pieces the tangram represents not only the people, places and tasks of the Joint Action Project. It also stands for the layout of the township where every property looks different and every house or shack is individual, while it still adds up to a whole.



## THE COLOURS

### HIGHLIGHTING INDIVIDUALITY

The different shapes of the seven pieces are already indicating the diversity not just of the people working on the Joint Action Project, but also of the people for whom the project is set up. To underline the impression of an entity that is made of, by and for individuals we decided to choose a range of seven different colours. Some colours are within the same colour range and some are complementary. Combined they are adding up to the completed square without one colour outshining another.

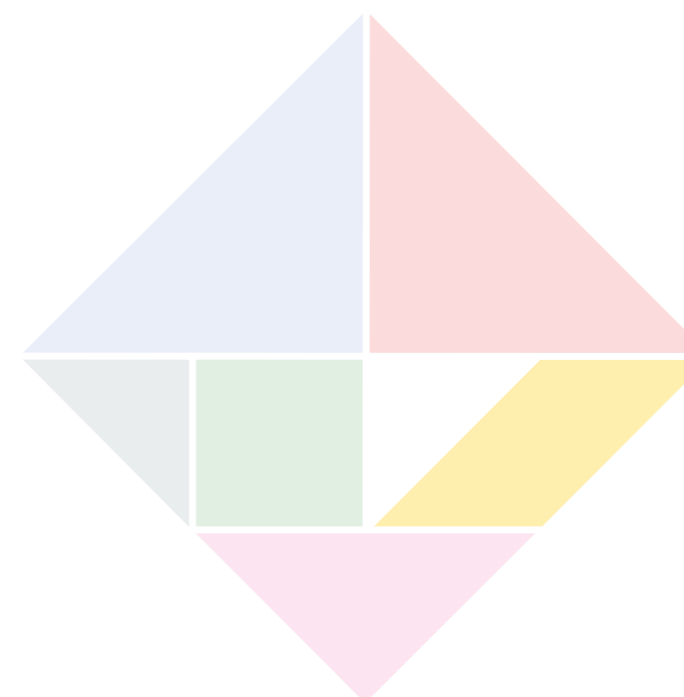

## THE GAP

### FINDING THE MISSING PIECE

The tangram of our logo is missing a piece. This «gap» represents our project that ought to fit in perfectly in the township environment and should be suitable for the beneficiary. The missing piece also shows the limited space we are working in (e.g. size of the actual site, surrounding structures) as well as the challenge of finding the type of structure that solves the task in the best possible way.

Filling the gap, and therefore finding a piece that fits in, also allows a lot more variation in re-arranging the tangram which hints at the various possibilities the soon-to-be-built structure could offer to the beneficiary in particular, but also to the local community.

# INTRODUCTION

## I.III ACADEMIC BASIS

*For about two months we joined academic Short Learning Programmes (SLP) at Nelson Mandela University in Port Elizabeth. We were advised in the fields of Development Studies, Human Settlements as well as Participatory Research and Design methods, each with relevance for our practical project activities.*



Action Research Mapping as a research tool



After the first seminar – Already one team



Working together was essential during the whole time



# HUMAN SETTLEMENTS

## «HOUSING PROBLEMS ARE EVERYWHERE»

We started from the very beginning of humankind, moved to the history of South Africa where we discussed the different mindsets of Africans and Europeans and concluded with the current challenges of urban development, focussing on informal settlements and their upgrading.

# DEVELOPMENT

## «THERE IS NOT ONE MASTERPLAN FOR DEVELOPMENT»

In lots of discussions we figured out an essential challenge not only of our student group, but of development theory in general: Everyone has a different, individual definition of development, even after we have discussed development theories, different approaches to it, how to measure development and if it can be measured at all (another huge discussion). But this course was not only about development, it also gave us an insight into research methodologies for a particular ward (in our case: Ward 4, Walmer Township) and how to use the data base of Statistics South Africa.

# IN-SITU UPGRADING

## «UPGRADING IS NOT ONLY ABOUT HOUSING»

A town planner who worked for the municipality of Nelson Mandela Bay facilitated the seminars of this SLP. And he started with a question we did not ask ourselves before: Why do we upgrade informal settlements? Moving on from this question we got to understand the in-situ upgrading approach better and how it differs from other upgrading approaches. While other approaches destroy the existing social and socio-economic structure of informal settlements by removing households, the in-situ approach tries to keep that structure that has been developed over a long period of time.

# PARTICIPATORY DESIGN

## «EVERYONE HAS SOMETHING VALUABLE TO CONTRIBUTE»

The last course was not a theoretical course. Instead we got to know some tools of participatory design and Participatory Rural Appraisal by experimenting with them ourselves. Keeping in mind that what we did in our little group is usually done with the members of the community you are working with.

The first part of the SLP was a toy block design exercise which is explained later (see p. 60). In the second part we mapped the area of Walmer Township using different materials, while trying to remember the resources we recognised during a visit of the township. The second step was to collect and prioritise the needs of the community with an outcome that underlined what we learned before: Upgrading or supporting a community is not done by only giving them a new house.



# DOCUMENTATION

HISTORY – ENVIRONMENT – RESIDENTS – MAPPING



# DOCUMENTATION

## I.1 INTRODUCTION AND IMPRESSIONS

*In Port Elizabeth's suburb of Walmer, spacious villas exist side by side with publicly funded RDP<sup>1</sup>-houses and cramped shacks of informal settlements. Those «two worlds» are separated by an old railway line. In this chapter we will highlight the unique history of Walmer Township, point out its characteristics, and show the very different types of housing.*



One of the oldest houses in Walmer Township



Metal sheets are a common building material



Rubbish piling up in unused corners

<sup>1</sup> RDP – Recreation and Development Programme, a socio-economic policy framework that, amongst others, seeks to provide adequate housing for every South African citizen.





A goat walking  
across an informal  
dump site



# DOCUMENTATION

## II.II HISTORY OF WALMER TOWNSHIP

Started as a farm in 1815, Walmer developed rapidly into a small town after it was laid out into plots that were sold in a public auction (1855) and became part of the municipality. Walmer Township itself was founded by two brothers in 1898. Its original Xhosa name «Gqebera» refers to the green hills and the adjacent valley, while «Walmer» originates from a British castle.

### EARLY HISTORY OF WALMER 1815–1898

While Walmer gained independent municipal status on April 22<sup>nd</sup>, 1899, the official history of the township only starts in 1902 when architect G.W. Smith created the layout of so called «Walmer Location».

### FIRST OFFICIAL LAYOUT 1902

The execution of the Group Areas Act reached Port Elizabeth: The plan was set to move all black inhabitants of suburbs, including the citizens of Walmer Township, into one area outside the city.

### THREAT OF REMOVAL 1961

### 1950 § GROUP AREAS ACT

The 1948 election marked the starting point of the era of Apartheid in South Africa. The government passed legislation to force the different racial groups to live and develop separated from each other. The Group Areas Act of 1950 was the base for the removal of mainly black inhabitants of suburbs to certain areas in the outskirts of the cities.

WALMER TOWNSHIP

SOUTH AFRICA

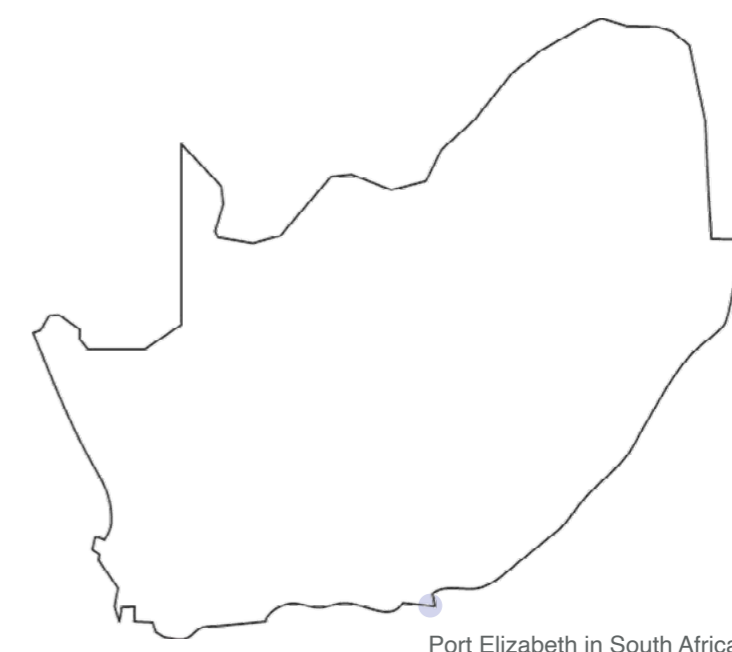

Port Elizabeth in South Africa

The municipality of Port Elizabeth declared that all residents of Walmer Township would have to move to Zwide 4 (New Brighton). The new area was located 22 kilometers away from Walmer, resulting in extra costs for residents for transport to and from work. Furthermore, rents were higher while the quality of infrastructure was significantly lower. Walmer Township residents protested supported by their neighbours from the white suburb wanting to keep their domestic workers close by.

The protests finally succeeded. The municipality officially announced that Walmer Township would stay where it was. Due to this specific historic context, Walmer Township offers a remarkable insight into the history of housing development in South Africa until today including some of the first RDP houses. For this reason it also has a special status among townships in Port Elizabeth.

WALMER TOWNSHIP PROTESTS  
1979

WALMER REMAINS  
1986

1962

ARREST OF NELSON MANDELA

Activist and freedom fighter Nelson Mandela was arrested for treason and his role in the resistance struggle. He was the leader of Umkhonto we Sizwe, the armed section of the African National Congress (ANC). He was sentenced to life in prison in 1963.

1994

DAWN OF A NEW ERA

Nelson Mandela became President of South Africa. He was the first black president elected in the first democratic election. Walmer Township grew in all directions, mainly in form of informal (non-authorized) settlements which are now slowly being upgraded and developed.

# PORT ELIZABETH

LOCATION OF WALMER TOWNSHIP

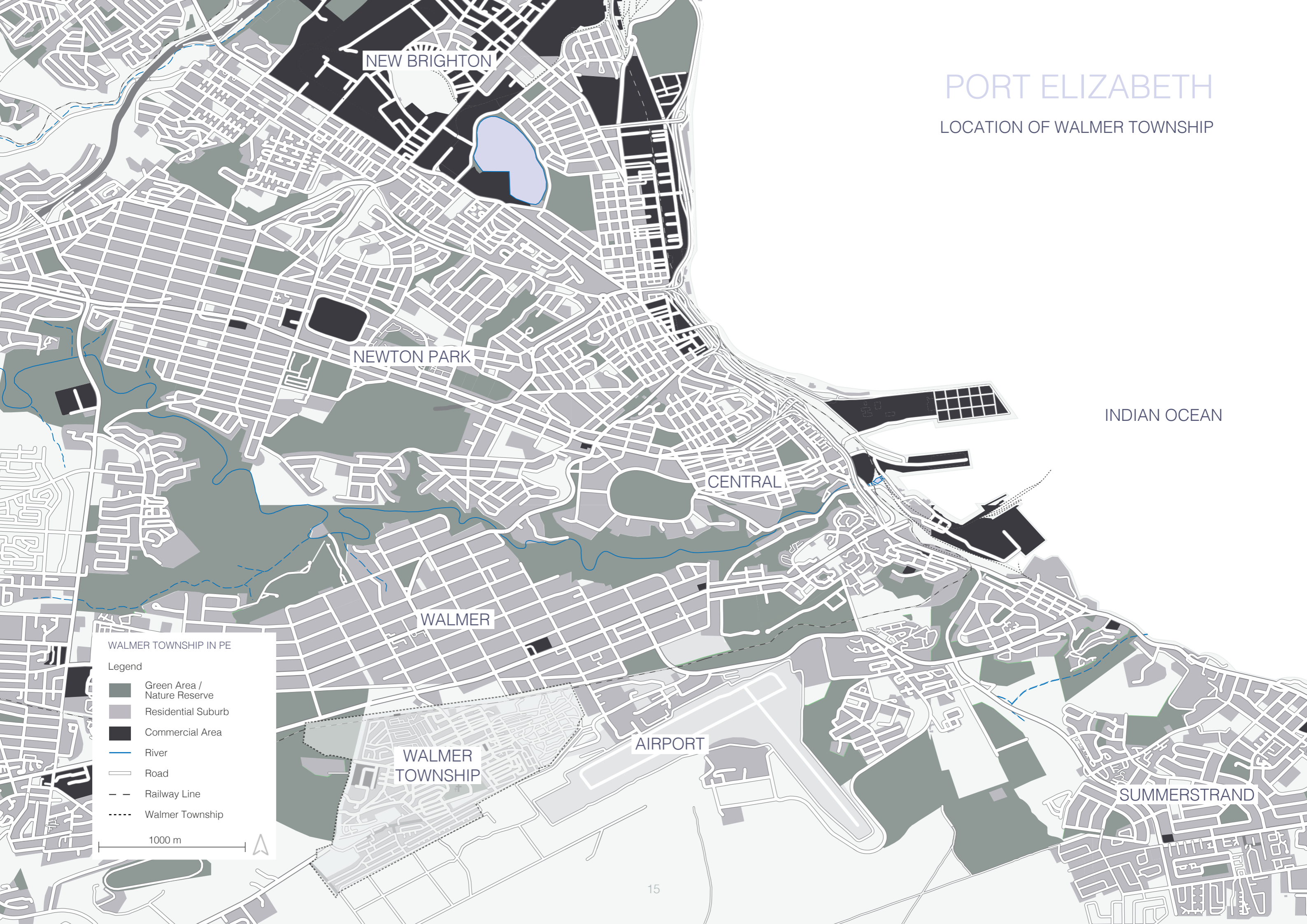

## WALMER TOWNSHIP IN PE

### Legend

- Green Area / Nature Reserve
- Residential Suburb
- Commercial Area
- River
- Road
- Railway Line
- Walmer Township

1000 m





# WALMER TOWNSHIP

MUNICIPAL SUBDIVISION

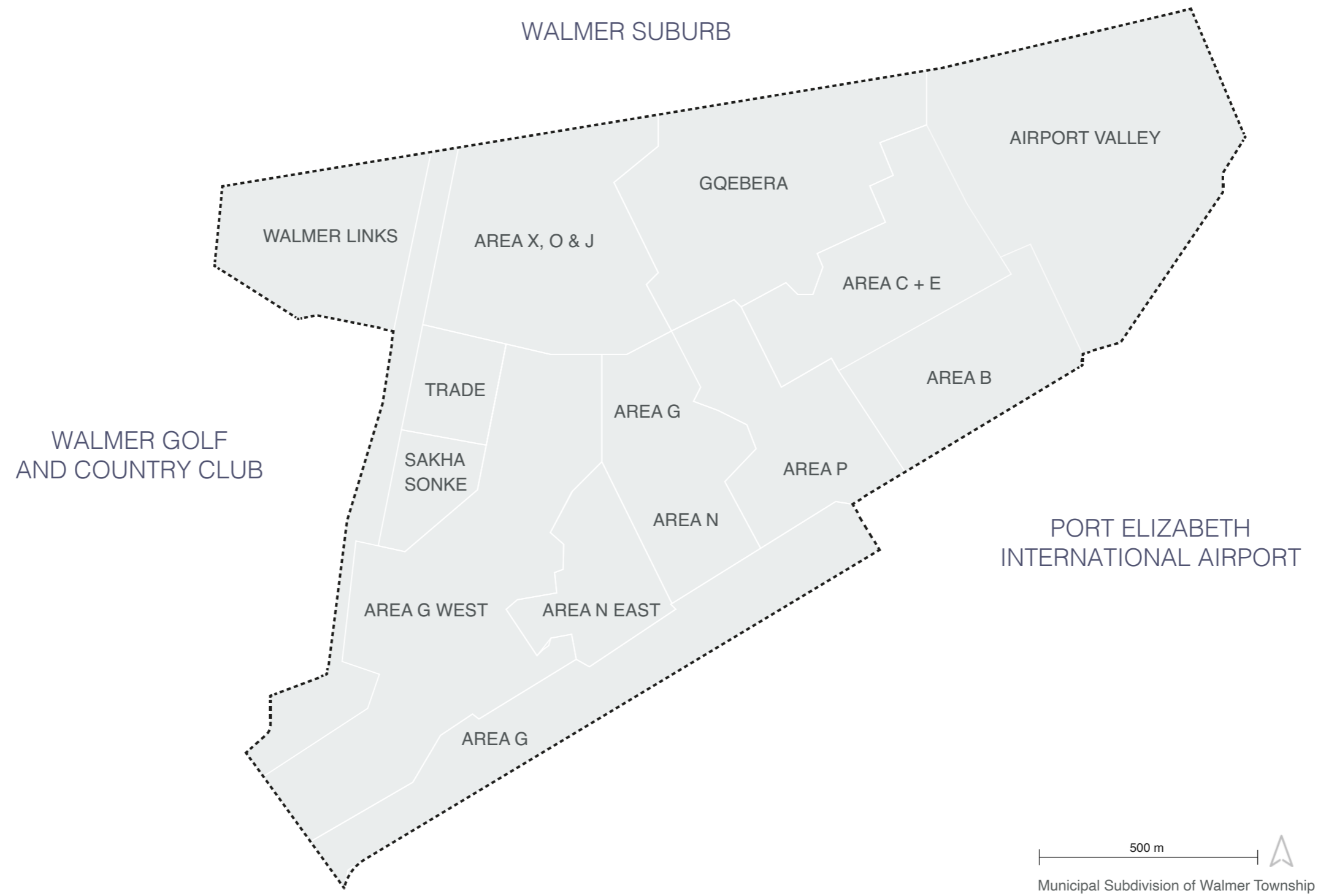

# DOCUMENTATION

## II.III KEY DATA AND BASIC INFORMATION

### PROFILE

Name: Walmer Township  
 Ward: 4  
 Councillor: Ayanda Tyokwana

Size: 1.74 km<sup>2</sup>  
 Households: 5,701

Unemployment: 35.3 %

### POPULATION

Population: 18,821  
 Black: 96.8 %  
 Coloured: 2.0 %  
 Indian/Asian: 0.1 %  
 White: 0.1 %  
 Other: 1.0 %

Age:  
 0-16: 30.3 %  
 17-35: 42.2 %  
 36-65: 27.0 %  
 > 65: 2.3 %

### HOUSING AREAS

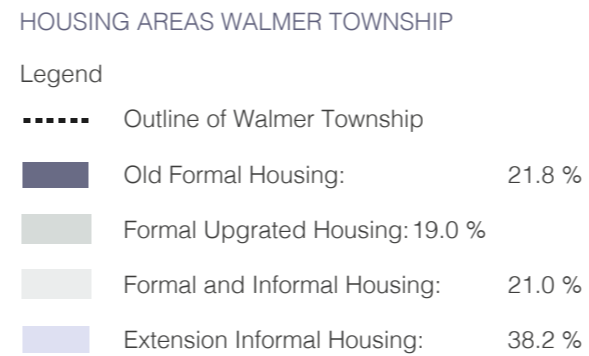
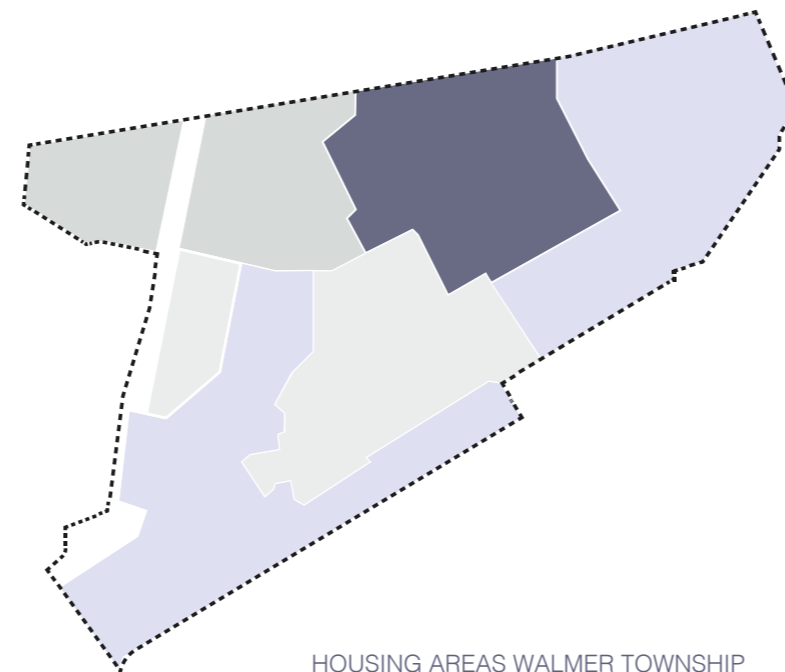

### SOCIAL ASPECTS

First Language:  
 isiXhosa: 85.5 %  
 English: 4.8 %  
 Afrikaans: 2.5 %  
 isiNdebele: 0.7 %  
 Other: 6.2 %

### EDUCATION

Education level:  
 None: 6.5 %  
 Primary: 8.6 %  
 Secondary: 57.2 %  
 Grade 12: 25.2 %  
 Higher: 2.4 %

### ECONOMIC ASPECTS

Monthly income per household (ZAR):  
 No Income: 18.2 %  
 1-4,800: 6.5 %  
 4,800-9,600: 9.0 %  
 9,600-19,200: 23.8 %  
 19,200-38,400: 24.3 %  
 38,400-76,800: 13.2 %  
 > 76,800: 5.0 %

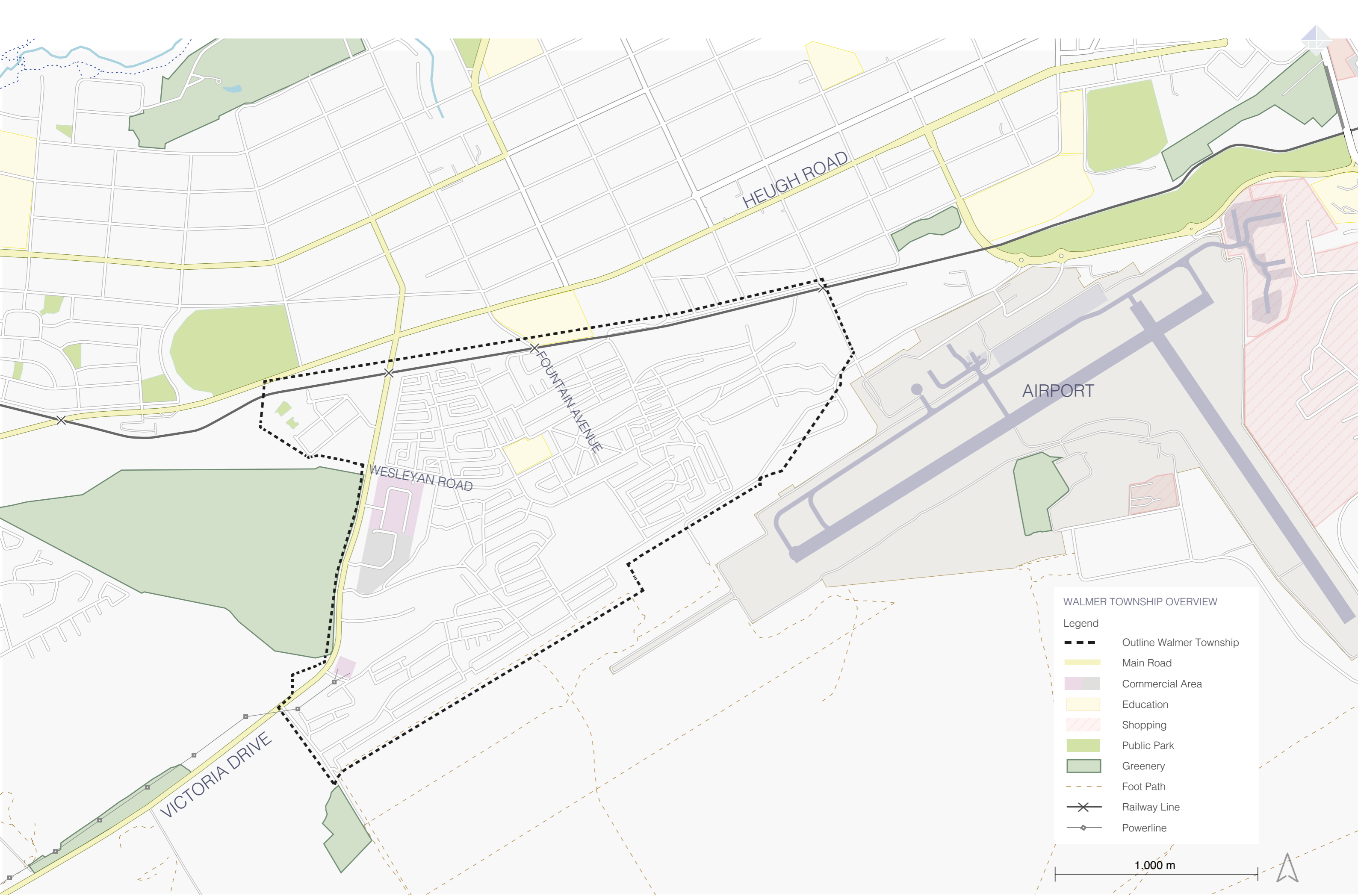

**WALMER TOWNSHIP OVERVIEW**

**Legend**

- Outline Walmer Township
- Main Road
- Commercial Area
- Education
- Shopping
- Public Park
- Greenery
- Foot Path
- Railway Line
- Powerline

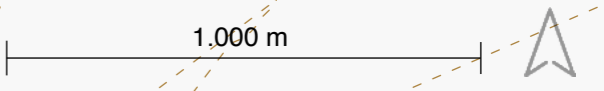

# DOCUMENTATION

## II.IV INFRASTRUCTURE AND SERVICES

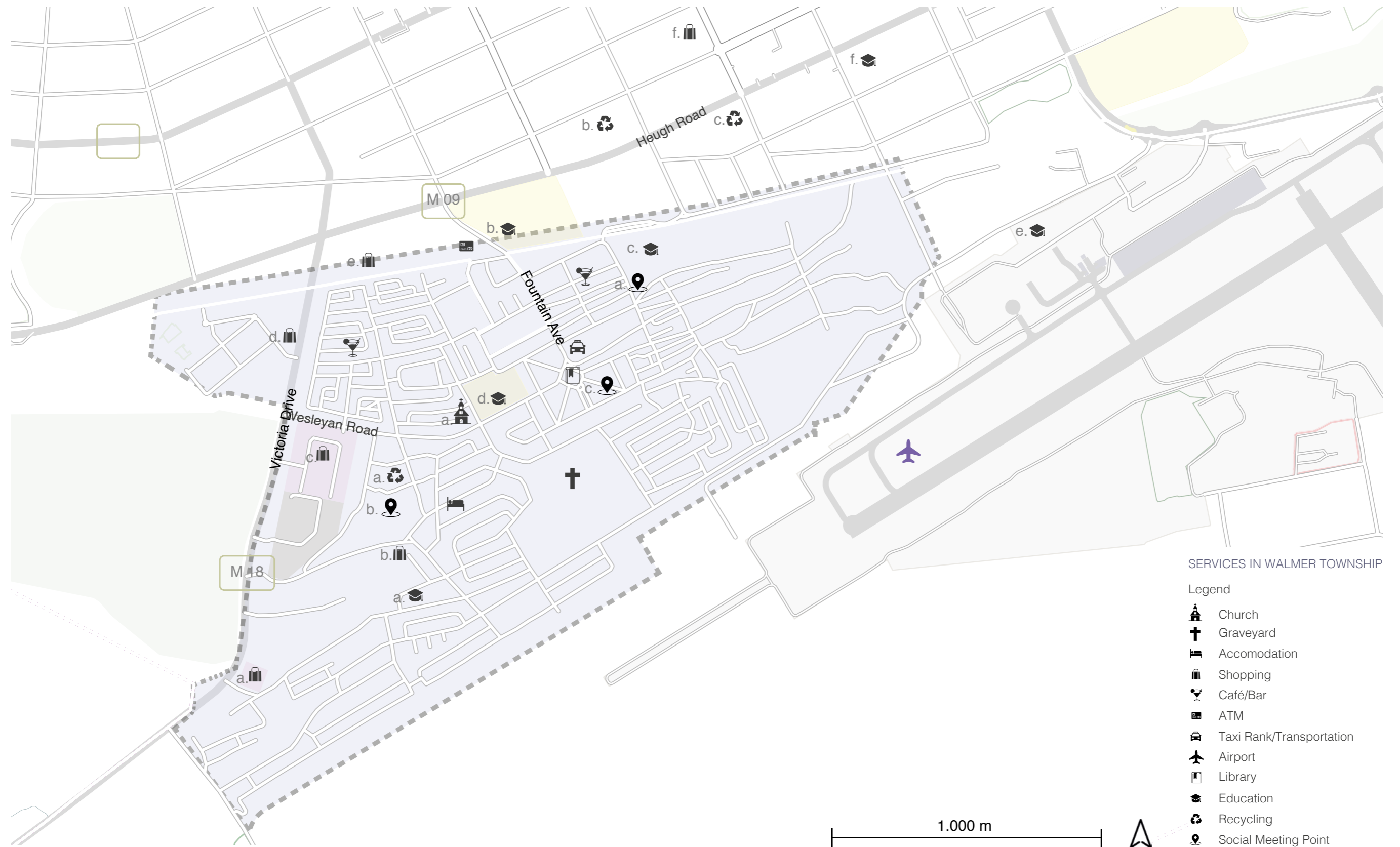





# INFRASTRUCTURE

## WASTE MANAGEMENT, WATER AND ELECTRICITY SUPPLY

- Water:** 57.2 % of the dwellings have piped water inside the property.  
A shared water tap outside the property is used by 42.3 %.  
0.5 % of the people do not have access to water.
- Sewerage:** There is a big difference between formal and informal areas.  
85.4 % of the formal residents have a flush toilet connected to the sewerage system (3.6 % of the informal residents).  
Informal residents mostly use bucket latrines (89.0 %).
- Electricity:** It is supplied from poles scattered throughout the township.  
Cables connect an in-house fuse boxes to the city's power grid.
- Waste:** Waste is mostly removed by authorities once a week.  
There are dumpsites on private properties in informal areas.





# TRANSPORT

## ROAD SYSTEM, PUBLIC AND PRIVATE TRANSPORTATION

- Streets:** There is a poorly developed road system, esp. in informal areas.  
Some streets (formal area) have been rebuilt recently.  
Fountain Avenue (rebuilt in 2017) – main access road to the township from Heugh Road  
Wesleyan Street – access road from Victoria Drive
- Public Transport:** Taxis are mostly used (taxi = minibusses that carry as many customers as possible; not comparable to german taxis).  
The main taxi rank is located next to the public library.  
Bus and taxi stops are scattered throughout the township.  
Main access for public transport is Fountain Avenue.
- Private Transport:** Only 8.3 % of Walmer residents have their own car.  
Many use bicycles to go to work (especially to Lovemore Park).

# SERVICE

## MUNICIPAL SUPPLY AND COMMUNITY SERVICES

-  **Recycling:** view on map: a. Greencycle, b. M & B Scrap Metals, c. Acurate
-  **Shopping:** small container businesses located along the main road  
view on map: a. Newrst supermarket , b. Malvern Car Sound and Security, c. Tricor Vw Used Parts, d. Walmer Link Shopping Complex, e. Jackalpo, f. Sixth Avenue Shopping Center
-  **Education:** view on map: a. Greenlight Educate, b. Walmer High School, c. Walmer Primary School, d. John Masiza Intermediate School, e. Madiba Bay School of Flight, f. Harvest Christian School
-  **Church:** view on map: a. John Masiza Church
-  **Other:** a. Gqebera Clinic, b. M4 Couriers CC c. ACVV

Community Center and public library are centrally located, easily accessible from all parts of the township via Fountain Road or Wesleyan Street.

# HOUSING

## CONDITIONS OF LIVING AND ACCOMODATION

View chapter «Diversity of Settlement» (p. 24):  
 Informal and formal areas, including old formal housing  
 Formal residential: 61.8 %  
 Informal residential: 38.2 %

**Size of Household:** There are mostly between 2 and 5 people per household (62.4 %).  
 26.1 % are single households.  
 0.5 % have more than 10 household members

# DOCUMENTATION

## II.V DIVERSITY OF THE SETTLEMENT

Housing in Walmer Township means diversity concentrated in a small space. The area consists of 38,2 % informal and 61,8 % formal residential housing, including old original districts and upgraded areas with RDP and new social housing (see map: «Housing Areas in Walmer Township»).

The township is densely populated; in total 5.701 households share a land surface of 1.74 km<sup>2</sup> which is owned by Nelson Mandela Bay Municipality (NMBM). In average, one household in Gqebera lives on a moderate property of 30,50 square meters. In contrast, in the white suburb Walmer privately owned properties have an average size of 185 square meters (Census Data 2011).

In Gqebera the property size correlates with the particular housing section in the township. Upgraded sites are based on layout plans with a checkerboard-like arrangement of plots, whereas in the informal housing section property lines are a result of unregulated development.

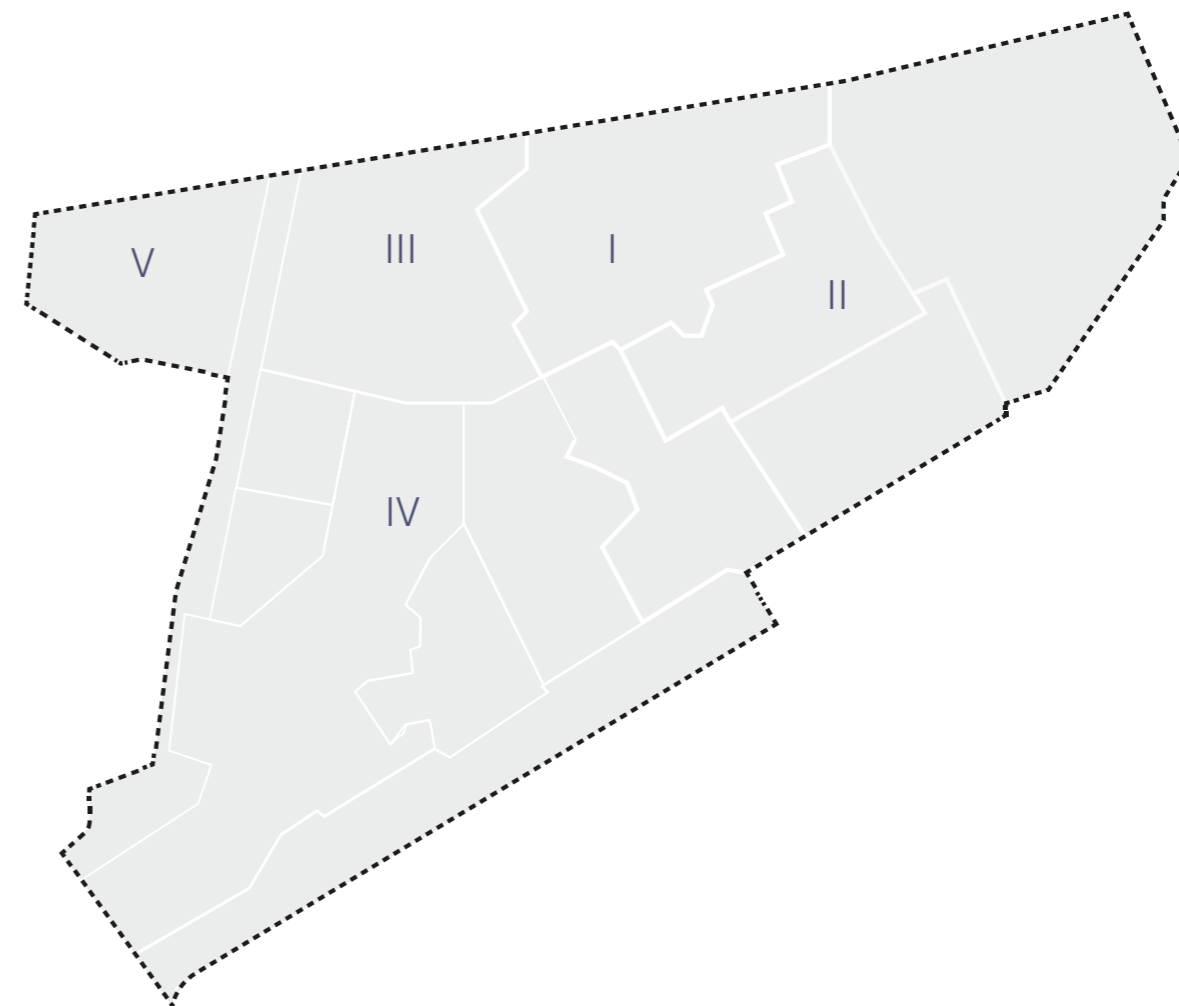

Location of housing types



Old formal area (Gqebera)

## I. OLD FORMAL HOUSING

EXTENDABLE, ONE-ROOM-HOUSE, HERITAGE

The first settlers of Gqebera (the old part of the township) moved into the urban area to work as domestic staff for the residents of Walmer suburb. Housing policy during this time became more and more about controlling the influx of black people into urban areas and the promotion of segregation.

The housing type in Gqebera is characterised by a small, one-room main house that is extended in various ways on most properties. It is around 50 m<sup>2</sup> in size with a separate toilet block. Materials used for extensions or add-ons are mostly corrugated iron sheets supplemented by a light timber structure.



## II. NELSON MANDELA HOUSING

BASIC DESIGN, 1994 - 2002



Nelson Mandela Houses

After the first democratic elections in 1994 the ANC government established the White Paper on Housing. The paper states new housing policies and strategies with the aim to «create viable, integrated settlements where households could access opportunities, infrastructure and services [...]»

In this context, the Reconstruction and Development Programme (RDP) followed. From 1994 until 2001 over 1,1 million low-cost houses were built by means of government subsidies. The target group were families who collectively earn less than R3,500 per month. They have a size of 38 m<sup>2</sup> and were meant to be an adequate basic shelter. Characteristics of the design are wooden doors and window frames and a roof made out of corrugated iron sheeting.

## III. RDP HOUSING

ADVANCED DESIGN, 2002 – NOW

In 2017, areas X, O and J of Walmer Township got upgraded with a provision of new RDP houses by the municipality of Nelson Mandela Bay. The 42 m<sup>2</sup> structure is an advanced design of the first Nelson Mandela House. Through the use of new technologies new building material got implemented, e.g. roof tiles, aluminium windows, a ceiling and insulation material. The living and dorm rooms are well proportioned, and the toilet was separated from the shower. A roofed entrance space («stoep») provides a sheltered outside space.



Upgraded RDP-houses





## IV. NEW SOCIAL HOUSING

### MULTISTOREY, STANDARD, MUNICIPAL

The Social Housing Programme (June 2005) aims at developing affordable rental housing in areas where bulk infrastructure (sanitation, water, transport) may be under-utilised. The newly offered flats range from bachelor and one-bedroom, to two-bedroom units from 44 to 57 m<sup>2</sup>. The flats are situated close to public services, education and business.



New social housing



Informal Housing

## V. INFORMAL HOUSING

### SELF-BUILT, SIMPLE, REUSED MATERIAL

Informal housing became closely connected with a lack of access to basic services, insecurity and poverty. Generally spoken, inhabitants are part of a low-income community who are not in compliance with building norms and urban planning regulations. The site is chosen for a limited period of time, boundaries are often shifted and context can change rapidly depending on individual needs of the residents. A shack represents one of the most dominant shelter types of South African townships. Housing characteristics are a private entrance, a single floor- and self-built structure made out of light-weight, mostly re-used material.

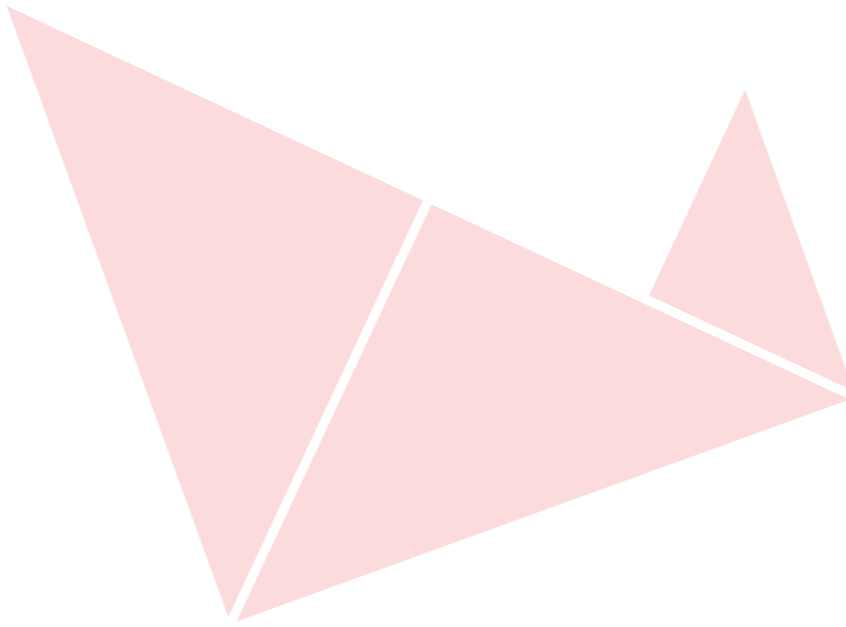

# SITE ANALYSIS

SITUATION – PROPERTY – FUTURE VISION



# SITE ANALYSIS

## III.I INTRODUCTION AND IMPRESSIONS

*Having lived in an informal settlement of Walmer Township for years, Khululekile aka «Khusta» Moko has adapted himself well to his surroundings. In his garden plants are growing well, and he can make a living out of waste-picking and trading the recyclables for food and necessities. But his dream is to actually run a real business in form of a work- and repair shop.*



Side entrance, access to daughter's accommodation



Sheltered outside sitting area



Foot path leading from the property towards the street





Entrance to Khusta's property lined by plants



# SITE ANALYSIS

## III.II MISSION OF THE PROJECT

### BACKGROUND

Khululekile «Khusta» Moko turned the negatives of his harsh reality into something beneficial by becoming a «waste picker». He manages to make a livelihood for himself and his family by collecting and re trading waste. Forming the economic basis of his life, he needs to carry, collect and store as much recyclable waste as possible.

### CONTEXT

Family Moko's home is in bad condition. The corrugated iron sheeting is leaking, the roof and walls are bending and the garden is not protected from burglary. There is not enough space to store and sort out the recycling material. A new home and workshop would create a huge positive impact on the family's living conditions, empowering Khusta to also run his own business as a craftsman.

### INTENTION

An international team of professors and students from South Africa and Germany is prepared to contribute to this change, continuing self-building activities started in 2017. In February 2020 they will work together on a three-week self-built project («Joint Action Project – JAP»). The interdisciplinary team is planning to build a new working and living environment for Khusta and his family, within practical workshops.

### PROGRAMME

Spatial programme: workshop, accommodation, garden  
Accommodation: living, cooking, sleeping spaces  
Size: 50 m<sup>2</sup>  
Special items: storage space and sorting facility



The design's approach is to become a forerunner of eco-friendly and self-feasible housing for people living in poor communities in South Africa. Sustainable housing and living includes social, economic and ecological aspects:

#### Safety

The new home should not arouse envy by its appearance. Living and working space ought to be carefully secured.

#### Smart Material

The construction is based on local resources and upcycled or reused building materials.

#### Empowering

The type of construction should be affordable for the majority of residents in Walmer Township which empowers people to do it themselves, thus spreading the Green Agenda. At the same time it serves as a start-up for a local business: Khusta's Re-Usables.

The design should be extendable. Construction has to take place parallel to demolition.

Waste Management. Upcycling. Design. Empowering. Community. Participation. Green Agenda. Sustainable Development. New Home. New Perspectives.

## APPROACH

## CONCEPT

## KEY WORDS

# ANALYSIS

## III.III NATURAL FACTORS

### WIND ROSE

#### FACING THE FORCES

Port Elizabeth is also known as «Windy City». Therefore air movement needs to be considered in particular. The wind rose provides information about frequencies, direction and speed of the wind. It can quickly indicate the dominant wind directions and the direction of strongest speeds. Angles are legible from the center position facing north in the front. The strongest winds in Port Elizabeth are from west-south west with wind speeds up to 20 mph, and from the opposite direction (east-north east) with the same speed but in minor frequencies. In contrast to the above north and south are quite windless directions.

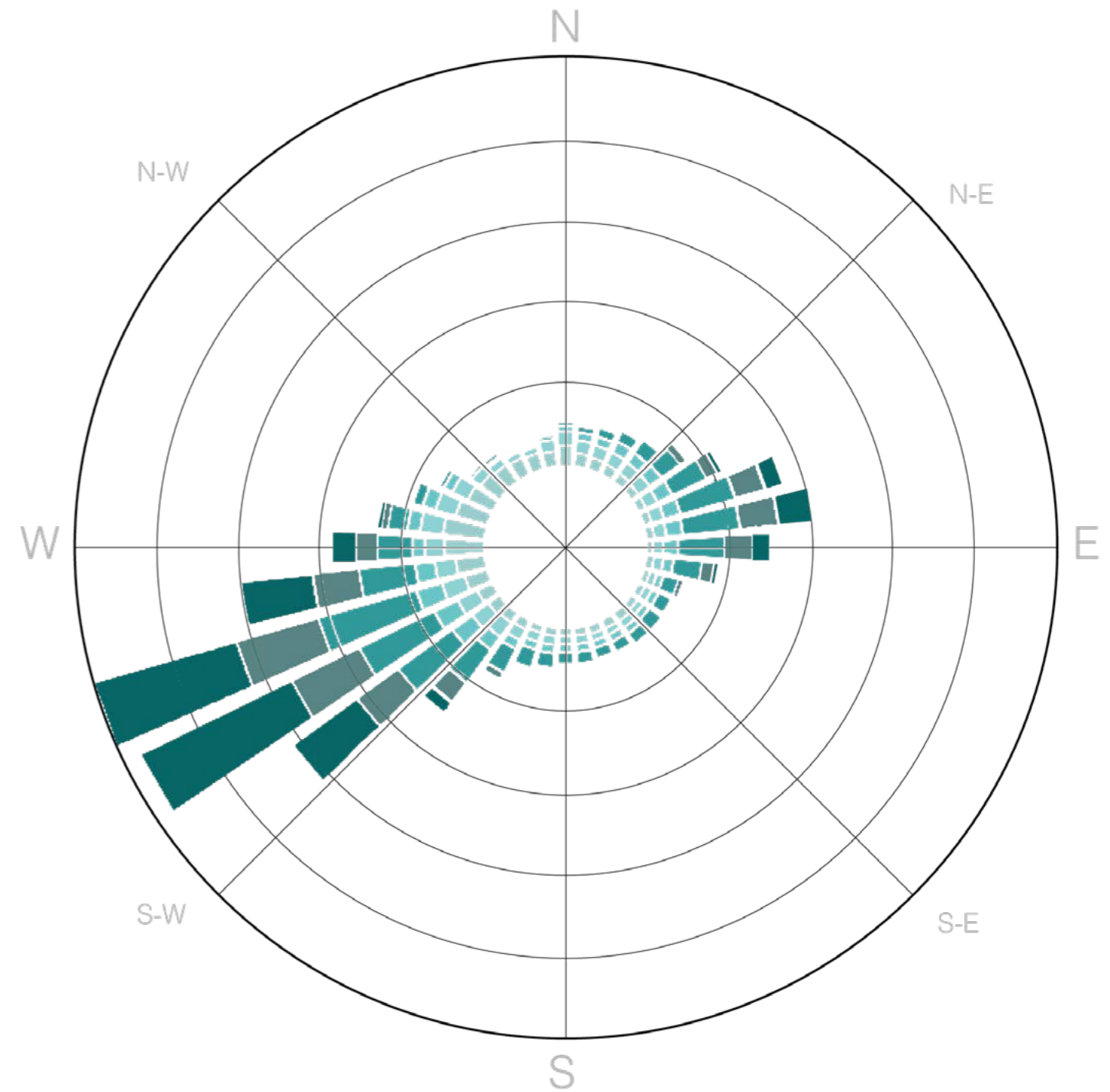

WIND ROSE PORT ELIZABETH

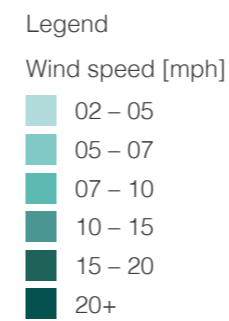



# SUN PATH

## FACING THE SUN

The solar angles change depending on the seasonal time, horizontally as well as vertically. From the center position of the left diagram all angles are readable with north straight ahead. Also the rising (east) and setting (west) position is different in all four seasons in time and noon angles. The spreading between maximum positions in winter (line above) and summer (line below) are diagrammed. In summer Khusta's home is subject to intensive radiation from early morning until late evening (80°, 04.45 - 19.15), while the winter days are short and the solar angle is shallow (32°, 07.15 - 16.45).

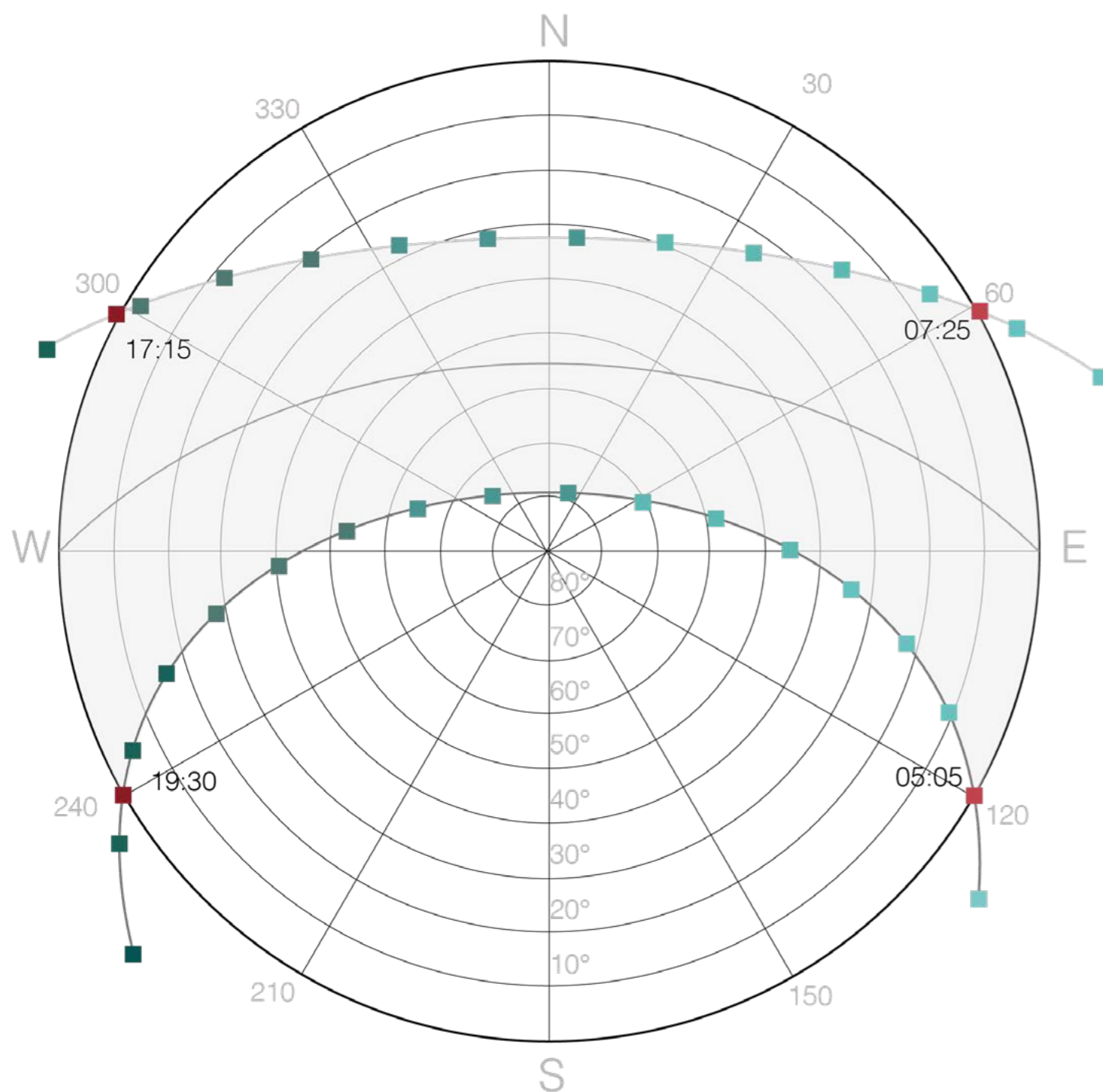

### SUN PATH PORT ELIZABETH

#### Legend

##### Time

- 00 – 02
- 03 – 05
- 06 – 08
- 09 – 11
- 12 – 14
- 15 – 17
- 18 – 20
- 21 – 23

##### Sun Path

- Annual Variation
- June Solstice
- Aquinox (Mar. and Sep.)
- Dec. Solstice

##### Sunrise/Sunset

- Sunrise
- Sunset

# SITE ANALYSIS

## III.IV SURROUNDINGS



### AERIAL MAP

Khusta is living in a self-built shack: separate toilet block, several smaller buildings, extensions to actual shack.  
He shares it with wife and daughter.  
Utilization of rest of property: gardening, storing re-usable waste



### FORM

Formal houses: arbitrary formation  
Building height between 1.5 - 2.5 m  
High building density  
More informal than formal housing



### GRID

Different sections: old township, upgraded, formal and informal part  
Extensions depending on needs and number of family members  
Unstructured grid of property lanes in informal sector; in contrast: upgraded area in the North

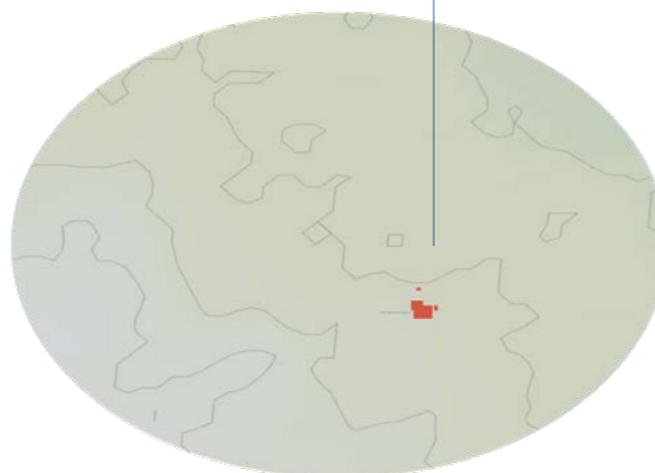

### TOPOGRAPHY

Relatively flat to undulating  
Dominating vegetation type: Sardinia Bay Forest Thicket  
Nature of soil: coastal, aeolianites ancient, wind-blown dunes, sandy ground





## GREENERY

Tall dense thickets, stunted trees, lianas  
Bushland before first settlers  
Gardening (vegetable bed, banana plants)



## TRAFFIC

Victoria Drive provides road access to urban area (with economic hubs) and airport.  
Wesleyan Street connects township centre with main road.  
Closest highway: M18  
Typical way of locomotion: taxis, walking, bike



## SERVICES

Electrical power: connection cable (yellow) to pole in immediate surroundings  
Water: tap down the road (shared by approximately fifty houses) (blue)  
Waste: municipal, weekly collection



## ORIENTATION

Noon angles of rising (east) and setting (west) vary in seasons  
Summertime: intense sun from early in the morning (80°, 04.45 - 19.15)  
Winter days: short, air radiation angle is shallow (32°, 07.15 - 16.45)

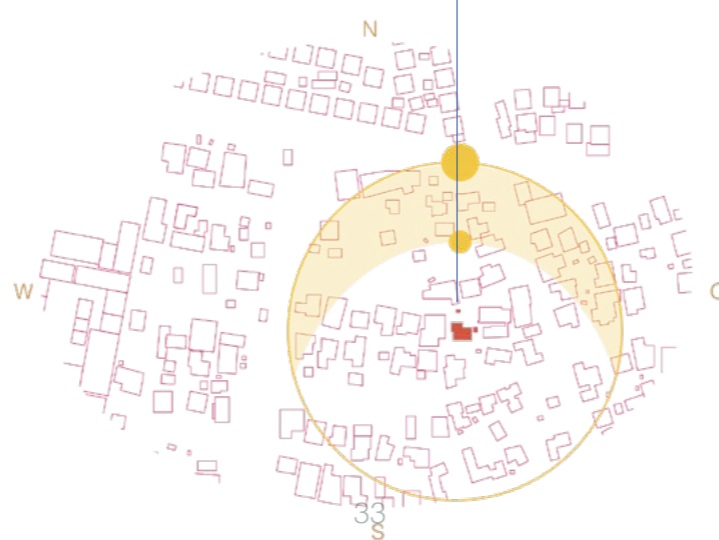

# SITE ANALYSIS

## III.V KHUSTA'S HOME



Khusta pointing out the electricity pole



Current storage area



The space between house and neighbouring property





# KHUSTA

## BENEFICIARY PROFILE AND SPECIFICS

Name: Khululekile Moko  
 Alias: Khusta  
 Age: 76  
 Mother Tongue: Xhosa  
 Spoken Language: Xhosa, English

Physical Address: G West 192, Walmer Township, 6011 Port Elizabeth

Living Situation: Family Moko moved to Walmer Township in 1974.  
 They live in the informal sector.  
 Khusta shares his shack with his wife, daughter and dogs.

Trade: Khusta is a waste-picker.  
 He trades recycable materials for food at Re-Trade which is about 4 km away from his home.  
 The non-profit organisation that operates the center supports the marginalised in the community by providing a trading opportunity and raising awareness of the environment.

Skills: Khusta is a tinkerer and craftsman.  
 He collects material and stores it at his property.  
 He builds, rebuilds and creates things that make his life easier (e.g. tow-bar for his bike to pull his pushcarts).  
 He also does small repair jobs (e.g. bikes, shoes) for other people.



Khusta

Location of his house



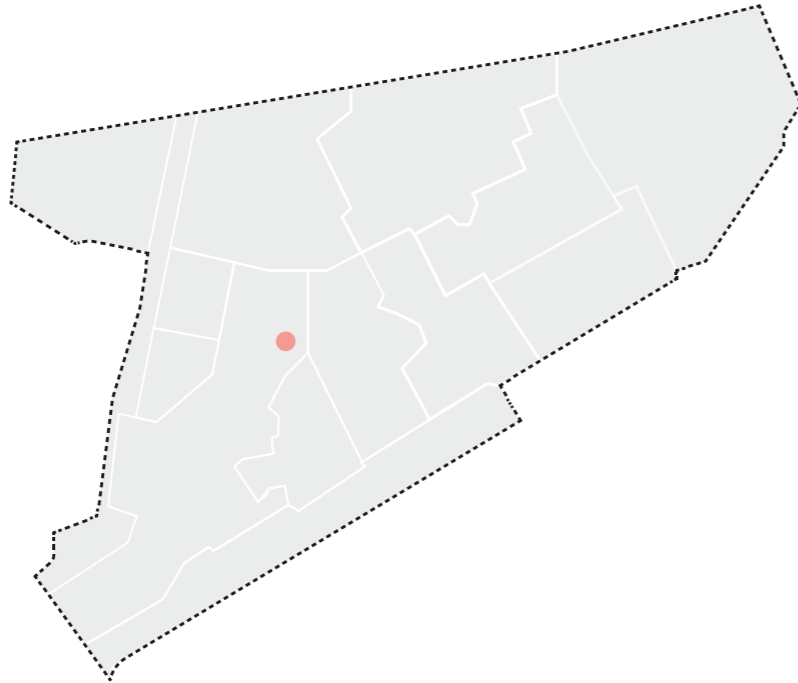

Location of Khusta's place in Walmer Township

## SITE PLAN

### BENEFICIARY'S PRESENT PROPERTY AND HOUSE

Plot Size:	120 m <sup>2</sup>
House Size:	45 m <sup>2</sup>
Area:	informal
Owner:	Khululekile «Khusta» Moko
Supply:	electricity via cable from a pole located in a neighbouring garden fuse box inside the house shared water tap approx. 70 m away from the property separate toilet block (bucket latrine) next to access from street
Service:	waste collection once a week by the municipality toilet clearing once a week by the municipality trading center is 3.90 kilometers away from his property
Transport:	owns a bike and several pushcarts path to his property measures 1.10 meters taxi stops 900 meters away from his property



GROUND PLAN: KHUSTAS PROPERTY

Legend

- Property Line
- Shack
- Foot Path
- Garden
- Vegetable bed

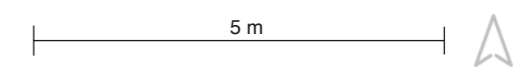

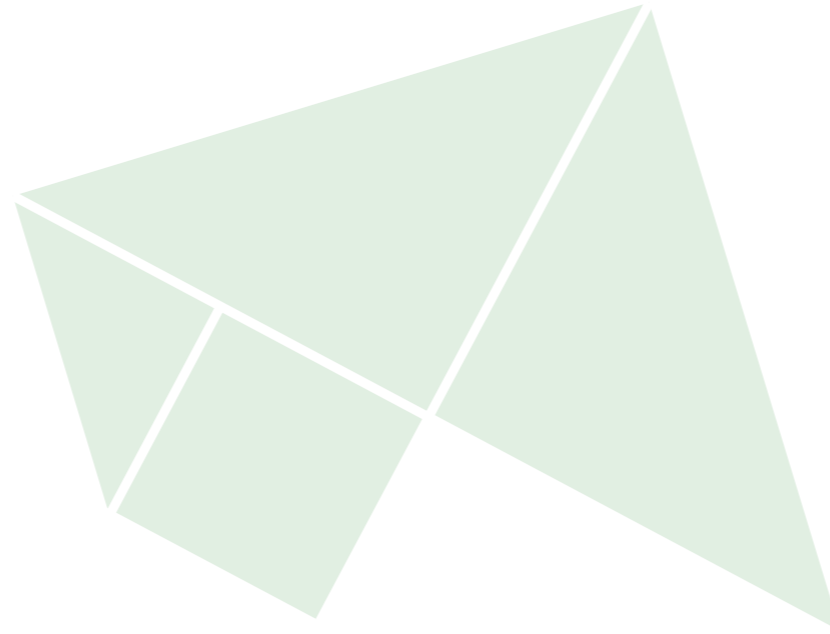

# PREPARATION

COORDINATION – MATERIAL – WORK SPACES – PUSHCART



# PREPARATION

## IV.1 INTRODUCTION AND IMPRESSIONS

*The basic ingredients for a successful self-building project are: a good and skilled team (which we have), well-equipped workshops (which we prepared) and lots of material which we can use for building. All this needs to be prepared and sometimes pre-treated before the self-built project can start.*



Dismantling bikes at Makerspace



Making Greenbushes theft-proof



Serious talking





Dismantling the fifth pile of pallets at PE College



# PREPARATION

## IV.II THE FIRST STEPS

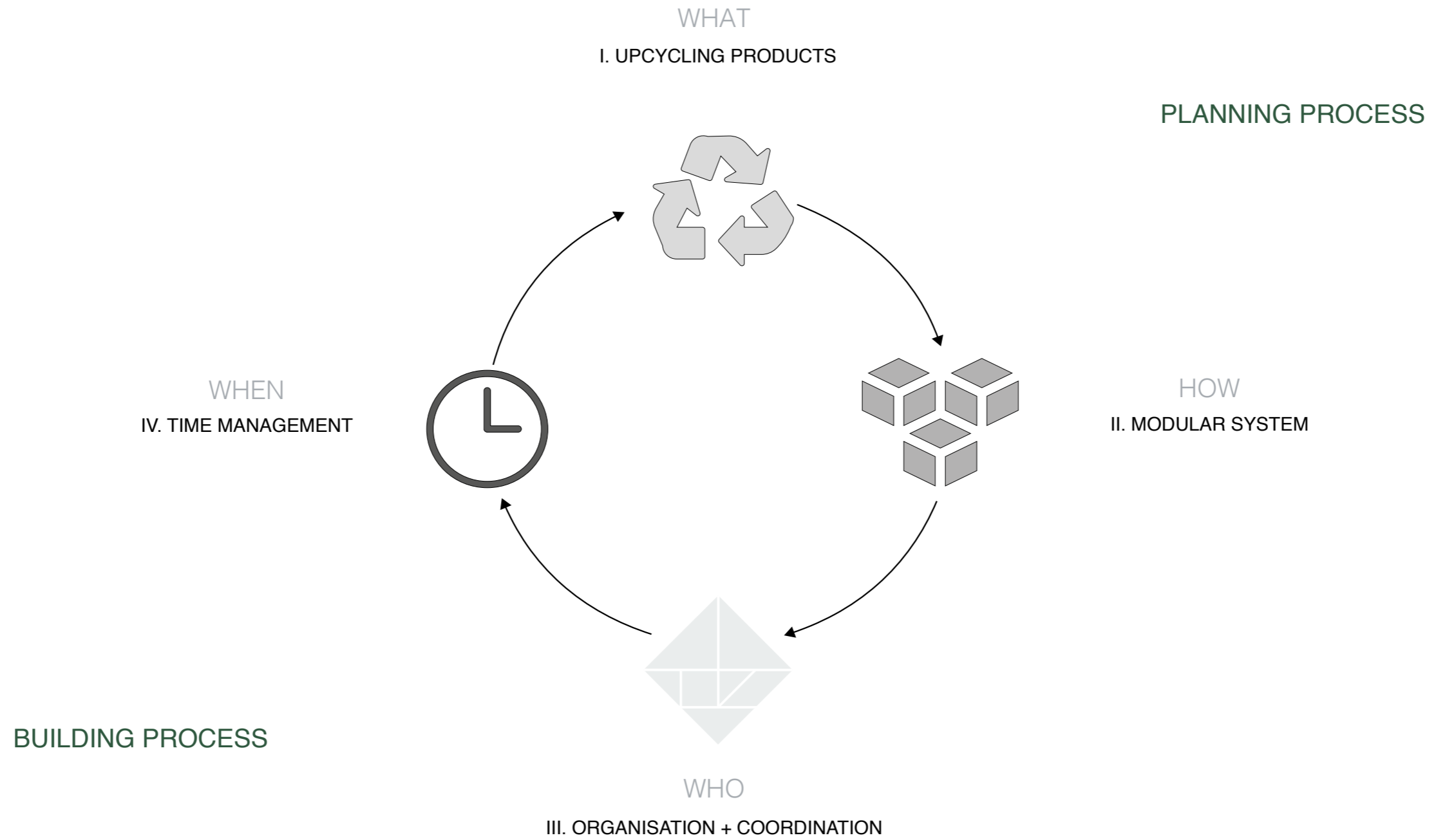





## UPCYCLING PRODUCTS

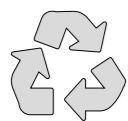

Approach: use of recycled building materials  
(environmentally friendly, cost-efficient)

Guiding

Questions: What material do we already have? (work space)  
What can we re-use of the existing structures  
on the beneficiary's site?  
What else do we need?  
Where we can get it from? (junkyard)  
Can we prepare it by ourselves, and how? (manual)

## ORGANISATION AND COORDINATION



Approach: Twenty-five team members will assist each other in small groups and need to be coordinated in February 2020.  
(productive group size, working hand in hand)

Guiding

Questions: Preparation work:  
How many groups do we need to implement the design?  
Which group size will be work-efficient?  
Which group is responsible for which steps of work?  
Where are they going to work?  
(Green Bushes / Workshop Valley / Walmer Township /  
Kevin's Studio / PE College)

## MODULAR SYSTEM

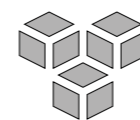

Approach: Simple, extendable and serial design  
(fast production and time-efficient installation)

Guiding

Questions: What kind of modular system is feasible?  
How can we produce elements - components - modules?  
How can they be independently pre-assembled in  
smaller groups?

## TIME MANAGEMENT



Approach: Time scheduling supports an orderly accomplishment of  
tasks (increasing the effectiveness and efficiency of work).

Guiding

Questions: Demolishing and building time – shifted or at the same time?  
When to demolish which part of the existing?  
When to build which part of the new design?  
When is which group in action on site?

# PREPARATION

## IV.III PLACES OF INTEREST



### PLACES OF INTEREST

#### Legend

- 1. Khusta's property (JAP site)
- 2. Kevin's studio (architectural office)
- 3. Makerspace (Valley Workshop) WERK\_2 (Workshop)
- 4. Green Bushes (storage)
- 5. Nelson Mandela University South Campus
- 6. PE College Struandale Campus
- 7. The Cottage (exchange students' accomodation)
- 8. Builder's Warehouse (hard ware store)
- 9. Former project sites in Joe Slovo
- 10. Students' Accomodation February 2020

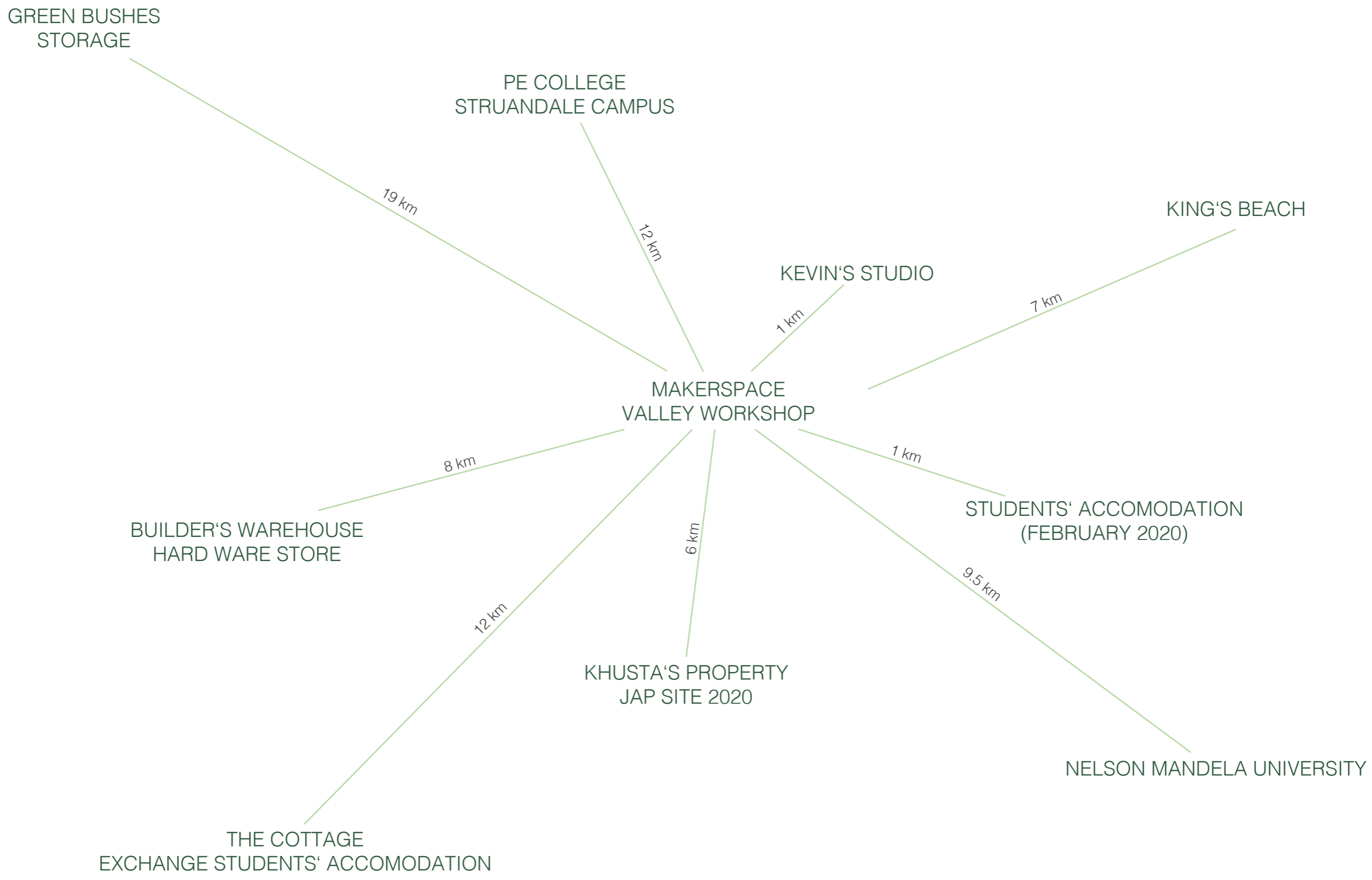



# PREPARATION

## IV.IV WORKSHOPS

### MAKERSPACE THE WORKSHOP IN THE VALLEY

- Address: Horton Street  
South End  
Port Elizabeth, 6001
- Facilities/Specifics: Lockable headquarter  
self-designed and self-built by the team  
surrounded by lots of free space  
Access to WERK\_2 (table saws,  
CNC, laser cutter, ...)  
Access to toilets and sanitary facilities  
Centrally located between all «places of  
interest» (see map)
- Typical Activity: Clearing the site from stones and rubbish





# PE COLLEGE

## SPACIOUS WORKSHOP AT TVET COLLEGE

Address: Struanway  
New Brighton  
Port Elizabeth, 5575

Facilities/Specifics: Part of the TVET College (contact: Mr Holmes)  
Access to machines (planer, saws, ...)  
Indoor workspace and some free space for working outdoors  
Access to toilets and washing facilities  
Small food facility on site (recommended for emergencies only)

Typical Activity: Planing timber poles

# GREENBUSHES

## STORAGE SPACE OUTSIDE THE CITY

Address: Waterkloof Road  
Greenbushes AH  
Port Elizabeth 6390

Facilities/Specifics: Storage space for wood, metal frames,  
metal sheets and Eco Bricks  
Former chicken stables, transformed and secured  
Outside the city on private property  
Shaded working area  
No shops nearby (but on the way)

Typical Activity: Dismantling wooden palettes (donated by Isuzu)



# PREPARATION

## IV.V BUILDING MATERIAL



### ECO BRICKS

- Dimensions: V = 2 l
- Characteristics: compressed waste into a 2L plastic bottle. It is packed tightly to ensure that it is unsquishable.
- Possible usage: Eco-bricks can be knotted with ribbon on a wooden sub-structure and covered with mortar.
- Cons: prone to animals, high expenditure of time, low strength capacity (depending on connection in between), not structural by themselves, different weights
- Pros: cost-efficient, environmentally friendly, recycling material, self-produced, insulating structure, colourful design, encourage participation







### COMPRESSED PAPER

Dimensions: 70/65/65  
Characteristics: glued recycled paper

Possible usage: interior walls, flooring, insulation

Cons: prone to fire and animals, not usable without supporting structure, no exact dimensions, requires preparation

Pros: organic material, cost-efficient, easy to work with, many design possibilities, locally available, insulating, high strength capacity



### PAPER TUBES

Dimensions: 10/46,5/46,5  
Characteristics: glue-laminated recycled paper

Possible usage: interior walls, furniture, gardening facilities, visual elements

Cons: prone to fire, animals and water, requires preparation

Pros: organic material, cost-efficient, easy to work with, many design possibilities, locally available



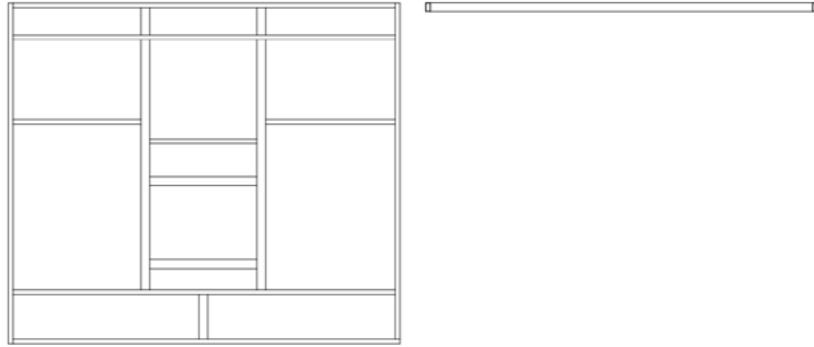

## METAL FRAMEWORK

Dimensions: 2600/2260/60  
 Characteristics: welded steel pipes,  
 rectangular or square cross sections

Possible usage: subconstruction, framework, lintels

Cons: precise welding essential, hard to work with  
 Pros: high strength capacity, not prone to water damage, mold, mildew,  
 and animals



## CORRUGATED IRON SHEET

Dimensions: 3000/2260/125  
 Characteristics: reused corrugated iron sheets, partly oxidized

Possible usage: covering structural devices: facade, roof cladding,  
 exterior and interior walls, visible element

Cons: partly oxidized: high risk of cracks and not fully water  
 resistant, weak bearing capacity, requires groundwork.  
 Pros: light material, not prone to animals, possible back  
 ventilation through right attachment, easy to work with

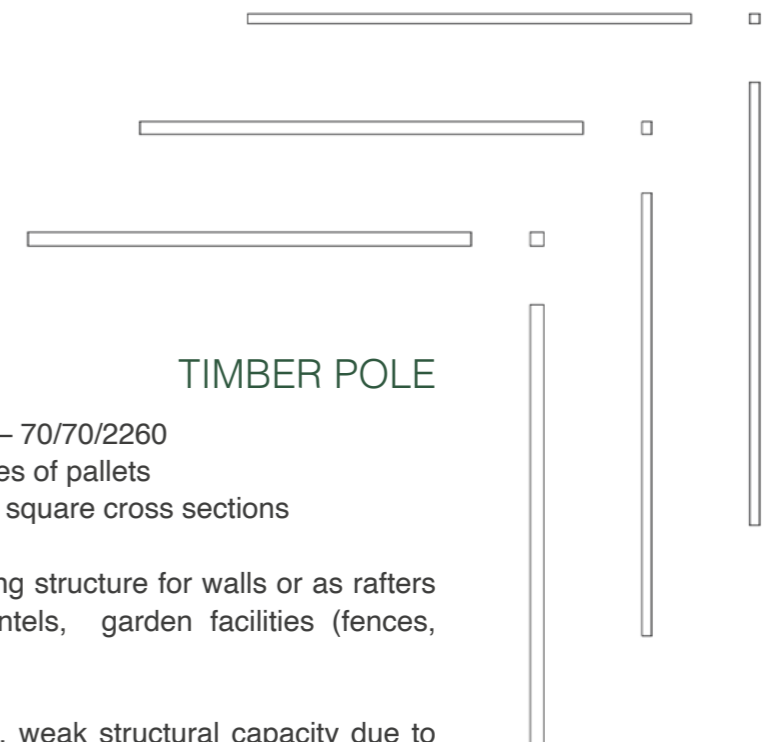

### TIMBER POLE

Dimensions: 50/50/2260 – 50/65/2260 – 70/70/2260  
 Characteristics: recycled substructural poles of pallets  
 solid wood, rectangular or square cross sections

Possible usage: bar system, light supporting structure for walls or as rafters and battens, columns, lintels, garden facilities (fences, bowers, extensions)...

Cons: prone to fire and animals, weak structural capacity due to second use of recycling material, high risk of cracks

Pros: organic, cost-efficient, locally available, easy to work with, many design possibilities, lightweight



### PLYWOOD BOARD

Dimensions: 2260/1220/10  
 Characteristics: glued sheets of wood veneer of recycled pallets

Possible usage: panel system, covering structural devices: flooring, paneling of exterior and interior walls, layers of building envelope, surface of structural elements, façade, visual element

Cons: prone to fire and animals, not structural, low strength capacity, no insulating capacity, adhesive sealing material

Pros: mainly organic material, cost-efficient, locally available, easy to work with, many design possibilities, lightweight





# PREPARATION

## IV.VI THE CART PROJECT



Discussing ideas



Final cuts at midnight



Showing Khusta the final cart



**PROJECT NAME** Pimp Khusta's Wheels!

**TASK** Redesign of a waste picker's push cart

**BENEFICIARY** Khululekile «Khusta» Moko

**RESTRICTIONS**

**Weight and Width**  
Foot path to his house is only 1.10 m wide.  
He has to take the cart in for security reasons.  
He has to pull the fully loaded cart for 4.5 km for trading.

**Road Safety and Visibility**  
He has to use a busy main road.  
His former cart got hit by a truck.

**Security and Theft Protection**  
His former cart got stolen from the property.  
Customisation and width play a mayor role.

**Customisation**  
It provides dignity.  
Everyone instantly knows to whom the cart belongs.

**APPROACH** Flatbed is the approved type of cart that works best for Khusta's needs.

Children's bike wheels are easy to repair and light-weight.

An easy-going steering is making it easier to pull.

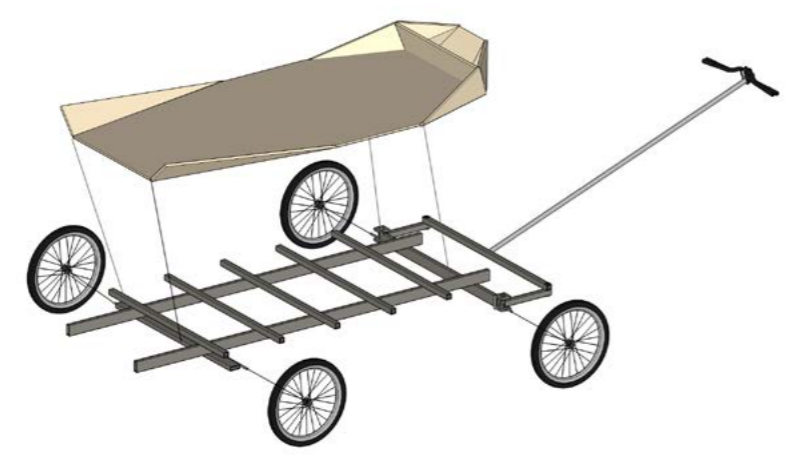

Explosion drawing

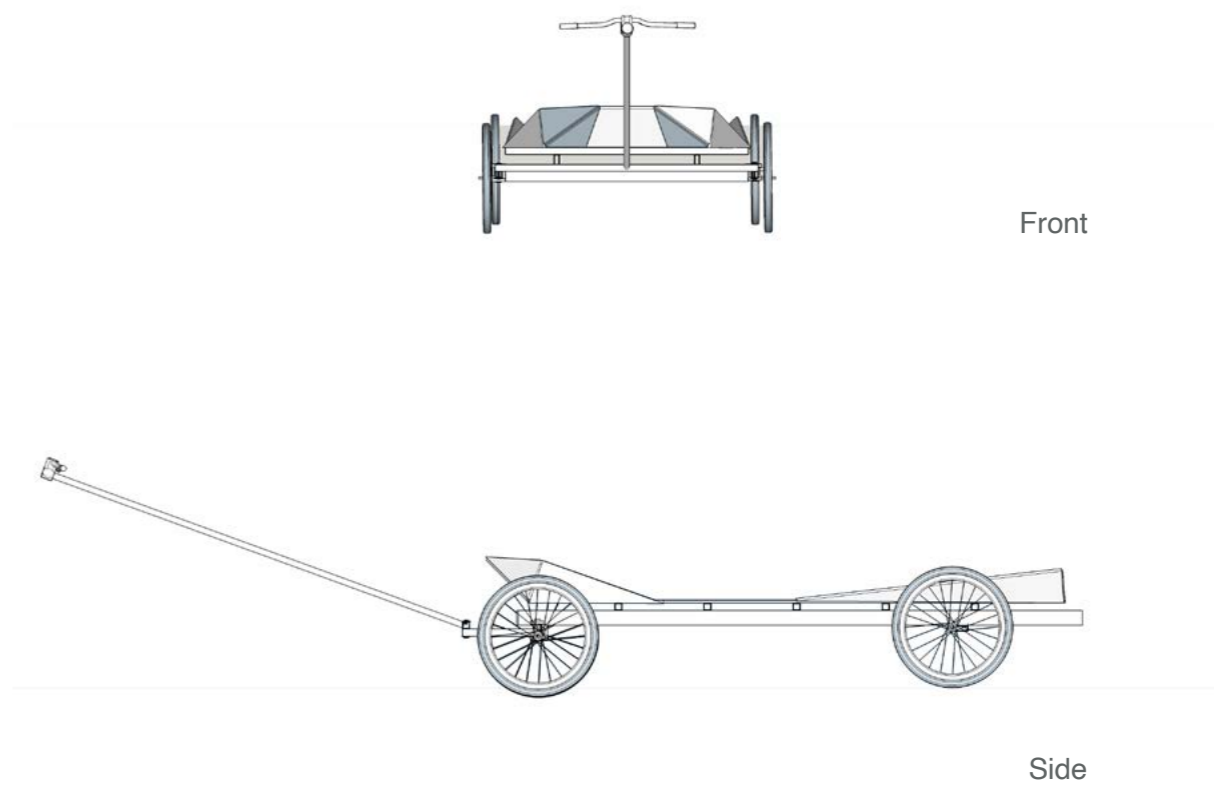

### SCHEDULE

- Day 1 – Design**  
A full day of collecting ideas, sketching and discussing.
- Day 2 – Finalising and Wheel Hunt**  
3D-sketches were keeping half of the team busy while the others looked around Port Elizabeth for suitable wheels.
- Day 3 – Welding the Frame**  
Using old delivery panels from the car industry, the frame came into life.
- Day 4 – Dismanteling Bikes**  
Finally two perfectly sized children's bikes were found, ready to be dismantled and serve a new purpose.
- Day 5 – Welding, Wood Work, Branding**  
For the last steps towards the finished cart a night shift was required.
- Day 6 – Final Assembly and Presentation**  
After a short night the final cart was presented, first to the sponsors, then to Khusta.

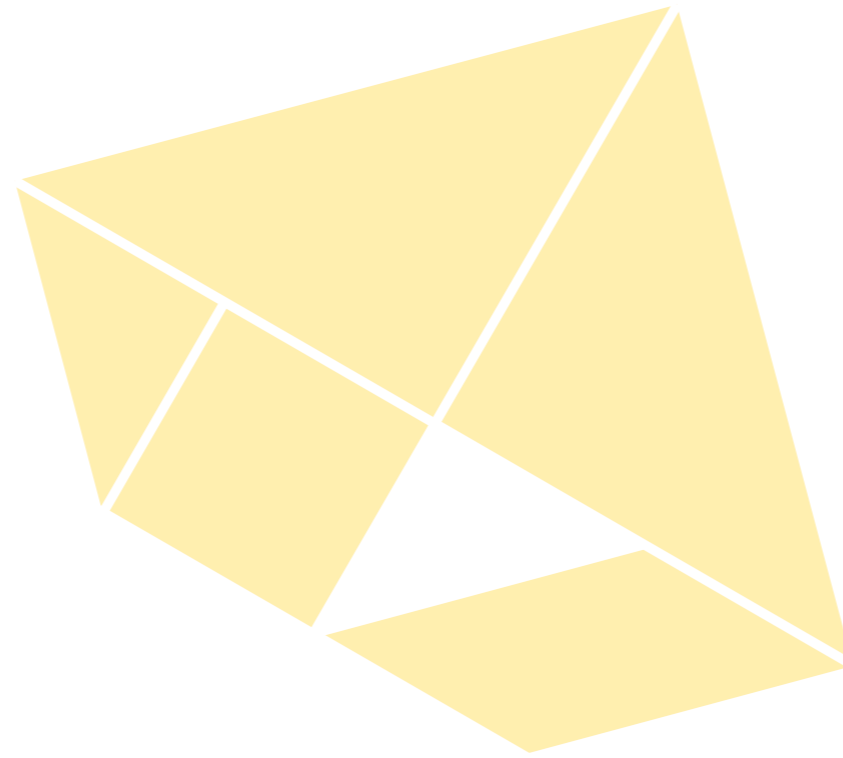

# CONCEPT

PARTICIPATION – SITE PLANS – TEAM WORK



# CONCEPT

## V.I INTRODUCTION AND IMPRESSIONS

*The way to our final design was long and literally «blocked». Using toy blocks for architectural design was part of the Short Learning Programme «Participatory Design and Action Research». It offered the chance to involve everyone, partaking in the programme, no matter if he or she had an architectural background or not.*



Discussion is a mayor part



Group design process



A first approach towards a final design



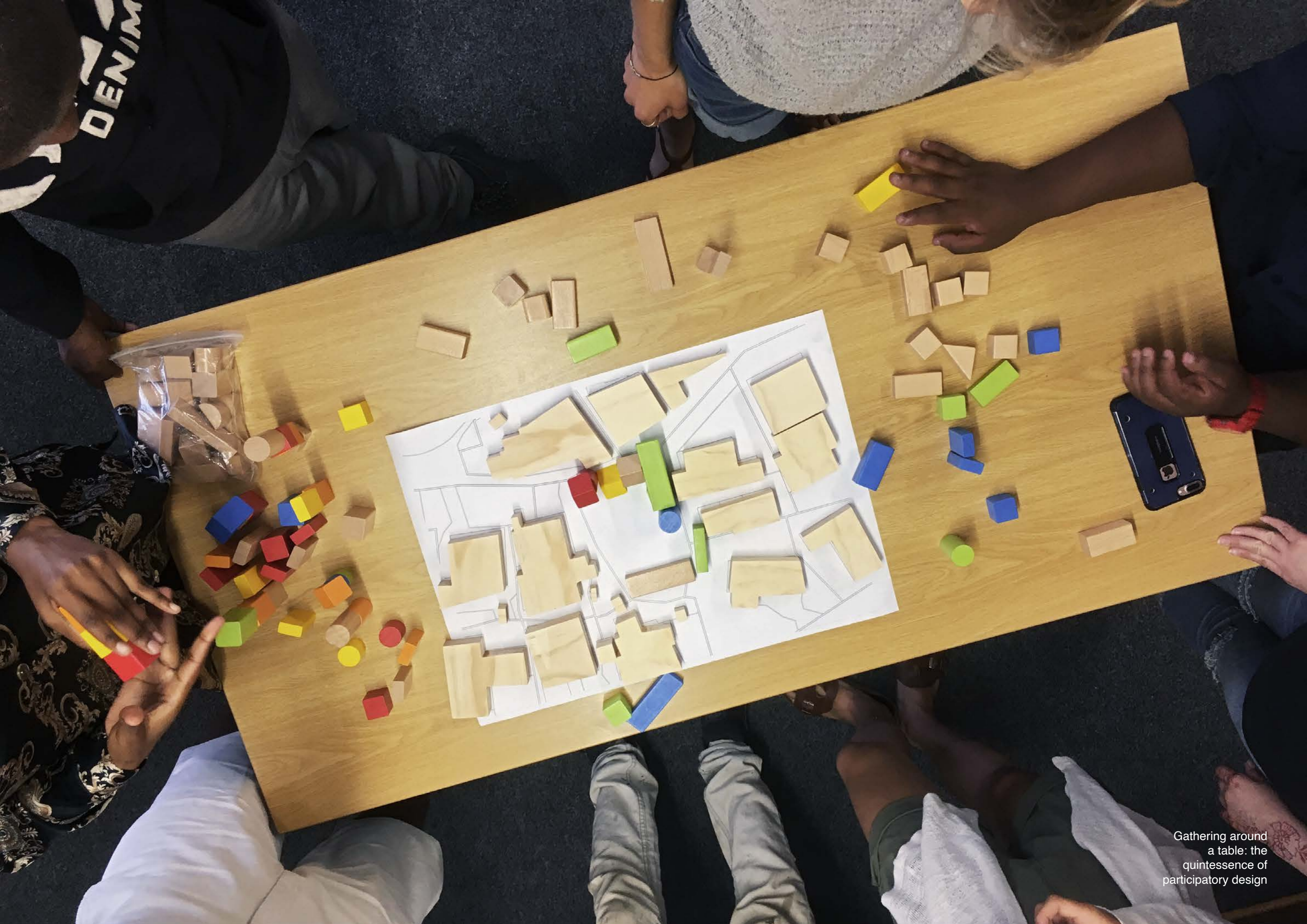

Gathering around a table: the quintessence of participatory design



# CONCEPT

## V.II PARTICIPATORY DESIGN PROCESS

### WHAT?

#### DEFINING PARTICIPATORY DESIGN

Before the actual design process could begin, there was an issue to solve: everyone and every discipline had a slightly different understanding of Participatory Design. Though one thing united every opinion from the beginning: Participatory Design involves more than only the designer, or in our case: the architect. Participatory Design means more people, more ideas, more knowledge, more experience, more discussions, more feedback from more fields. It is a quite democratic process where everyone has a voice and every single voice counts the same, no matter whether you are an architect, civil engineer, human settlement expert, communication designer, electrical engineer or development researcher.

### WHO?

#### TEAMING UP IN GROUPS

We split our group into two teams of three and one team of four. Every team was composed of at least one German and one South African student. Team «Architecture» included Alena, Kelsey, Sbu and Uta. Team «Urban» consisted of Jana, Lelethu and Likhona. And last but not least Dumisani, Mara and Sne were Team «Product».





## HOW?

### RELEASING THE INNER CHILD

Our design process did not start with pencil and paper but with toy blocks, one of the oldest toys in the world. In different teams we tried to find a solution for a new layout of Khusta's site. Blocks were moved around, colour codes implemented, new ideas developed and discarded.

The result were three completely different design approaches:

1. complete demolition of the existing structure and erection of a new one (staged construction)
2. direct extension of the existing structure
3. erection of a new structure independently from the existing

The fine-tuning of each design was an individual task so that we had ten different ideas at the end of day two.

## AND NOW?

### MOVING ON FROM HERE

Day three of the design process started with lots of discussions. What are the strengths of each design approach? Why is it a strength? Or is it a weakness? What are the weaknesses? Which facts do we have to consider in the further process?

Out of the ten individual designs (see p. 66) we collected the strongest points. With their help we became aware of the weak points we needed to wipe out. Final decisions were made: We want to include rainwater tanks. Workshop and storage should be separated from the living spaces. The dog's house will be in the front due to security reasons. The daughter's privacy is kept by having an individual flat for her own. And eventually we will extend Khusta's house towards the back (see «Building in Phases», p. 78).

For finalisation we all gathered around the table. After another round of discussions about positions, colour codes and sizes, a lot of moving blocks of different colours around and some construction work on the sides of the ground plan we finally defined our layout.

# CONCEPT

V.III GROUP CONCEPTS AND PROFILES

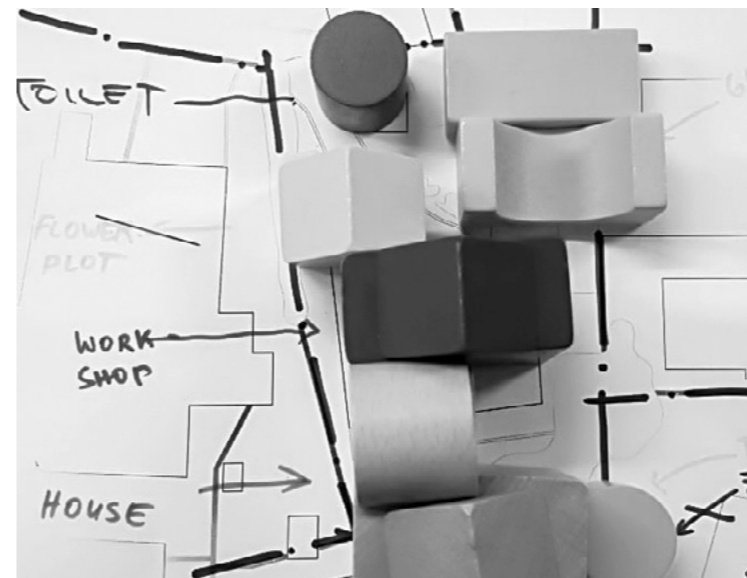
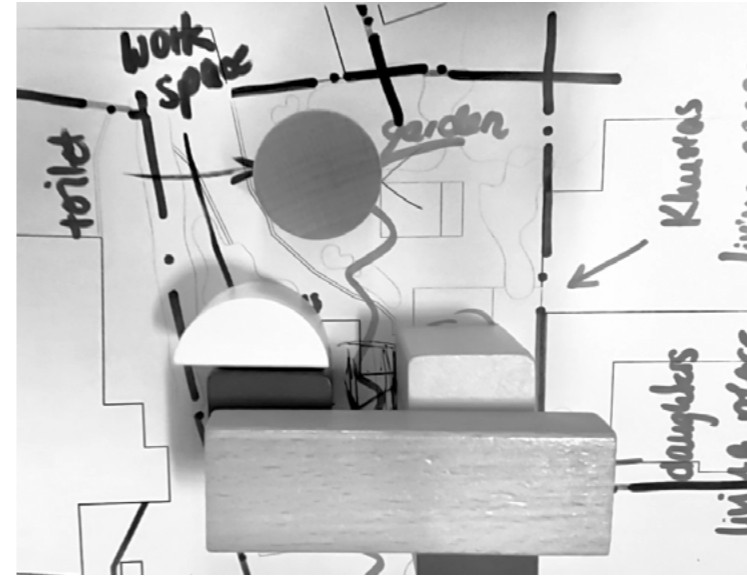

URBAN

PRODUCT

ARCHITECTURE



# URBAN

## EXTEND THE EXISTING

- living space: old house stays but is extended to the back (new living space in the back)  
separate flat for daughter
- working space: old structure (front) used for workshop and storage of material  
dogs in front – safe-guard
- sanitary: toilet stays in front (due to emptying the bucket by the municipality)
- sustainability: garden, business options
- strong points: no demolition necessary – emotional value  
dogs in front – security
- weak points: old structure – risk of collapsing  
garden removed from the back

# PRODUCT

## KEEP THE EXISTING

- living space: old house stays (separate flat for daughterstays as well)  
reorganising and new furnishing
- working space: new-built structure in the front for working and storing materials and carts  
dog’s house integrated – safe-guard
- sanitary: toilet stays in front (due to emptying the bucket by the municipality)
- sustainability: garden, solar panels on the roof, business options
- strong points: no demolition necessary – emotional value  
separation of working and living
- weak points: old structure – risk of collapsing

# ARCHITECTURE

## REFRAME THE EXISTING

- living space: old house is demolished in stages  
newly implemented structure (separate flat for daughter)
- working space: new-built structure next to the living space separated by a path between structures  
dog’s house integrated – safe-guard
- sanitary: toilet stays in front (due to emptying the bucket by the municipality)
- sustainability: garden, business options
- strong points: new structure – appealing  
separation of working and living
- weak points: demolition necessary – loss of self-build shack and emotional value



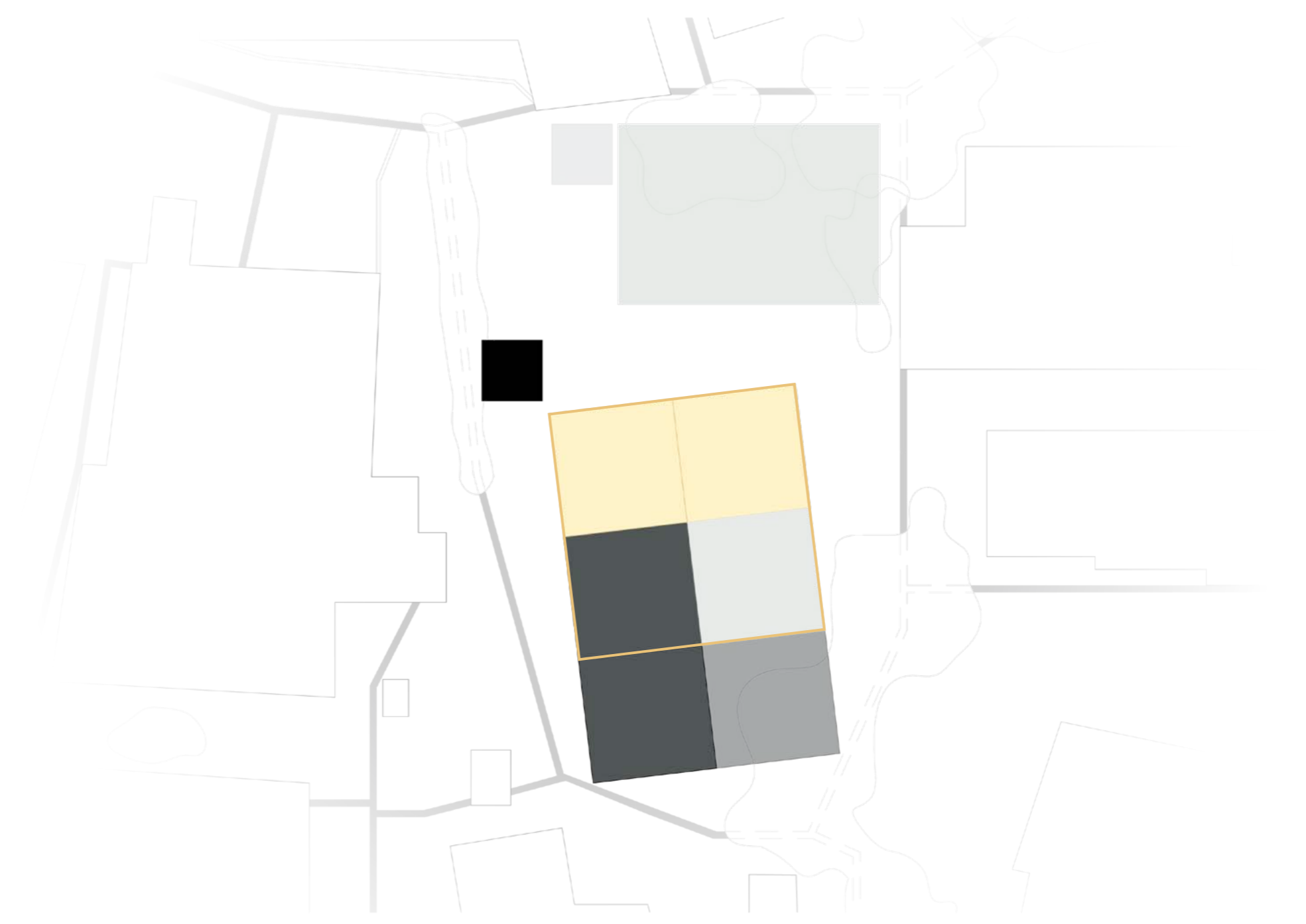

EXTEND – CONCEPT TEAM URBAN

Legend

- Workspace and Storage
- Dogs
- Parents – Kitchen/Living/Sleeping
- Daughter – Living/Sleeping
- Toilet
- Garden
- Existing Structure

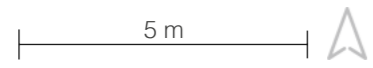



# JANA ARCHITECTURE



languages: German, English, Old Greek, Latin

skill set: Design skills - Digital Design (AutoCAD, ArchiCAD, SketchUP, Vektor Works, etc. Adobe Programmes)  
Analytical and problem-solving skills  
Team-building skills and organisation  
construction knowledge and building skills  
knowledge of green building materials and recycling

spirit animal: baby donkey



# LELETHU DEVELOPMENT STUDIES AND ECONOMICS



languages: isiXhosa, English

skill set: developing and implementing methodology  
efficiency  
usage of special research tools to assist in data collection and analysing the results  
Microsoft Office and Project Management software  
leadership and communication  
problem-solving skills  
documenting, capturing (Photography) and reporting (written feedback)

spirit animal: cat



# LIKHONA DEVELOPMENT STUDIES



languages: isiXhosa, English

skill set: Development policies  
social movements and change  
economics

spirit animal: butterfly





# DUMISANI

## HUMAN SETTLEMENT DEVELOPMENT

languages: English, isiZulu, isiXhosa

skill set: project management  
executive administration  
problem solving  
organising and coordination  
innovation  
service focus skills

spirit animal: wolf

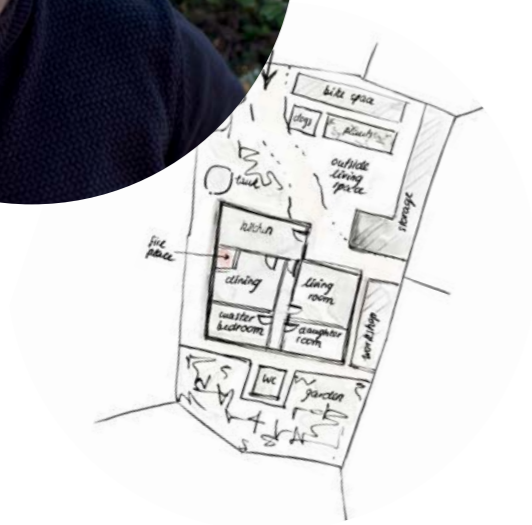

# SNE

## ELECTRICAL ENGINEERING

languages: isiXhosa, English, isiZulu

skill set: electrical wiring (low voltage)  
installation of PV Panels and solar water geyser  
working with Programmable Logic Controllers  
wood work, metal work  
team player  
ability to work under stressful conditions and communication skills

spirit animal: panther

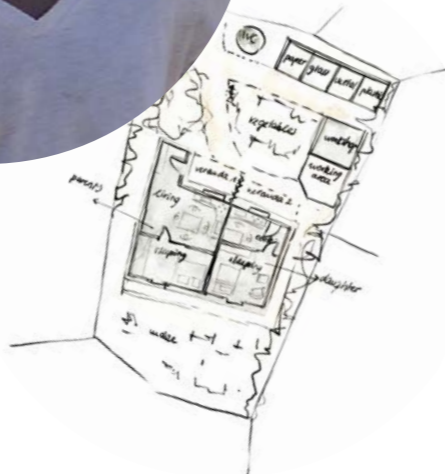

# MARA

## COMMUNICATION DESIGN AND MEDIA

languages: German, English, Russian

skill set: photography and layout  
writing and journalism  
video and film incl. editing and post-production  
Adobe programmes: InDesign, Illustrator, After Effects, Photoshop, Premiere

spirit animal: fox





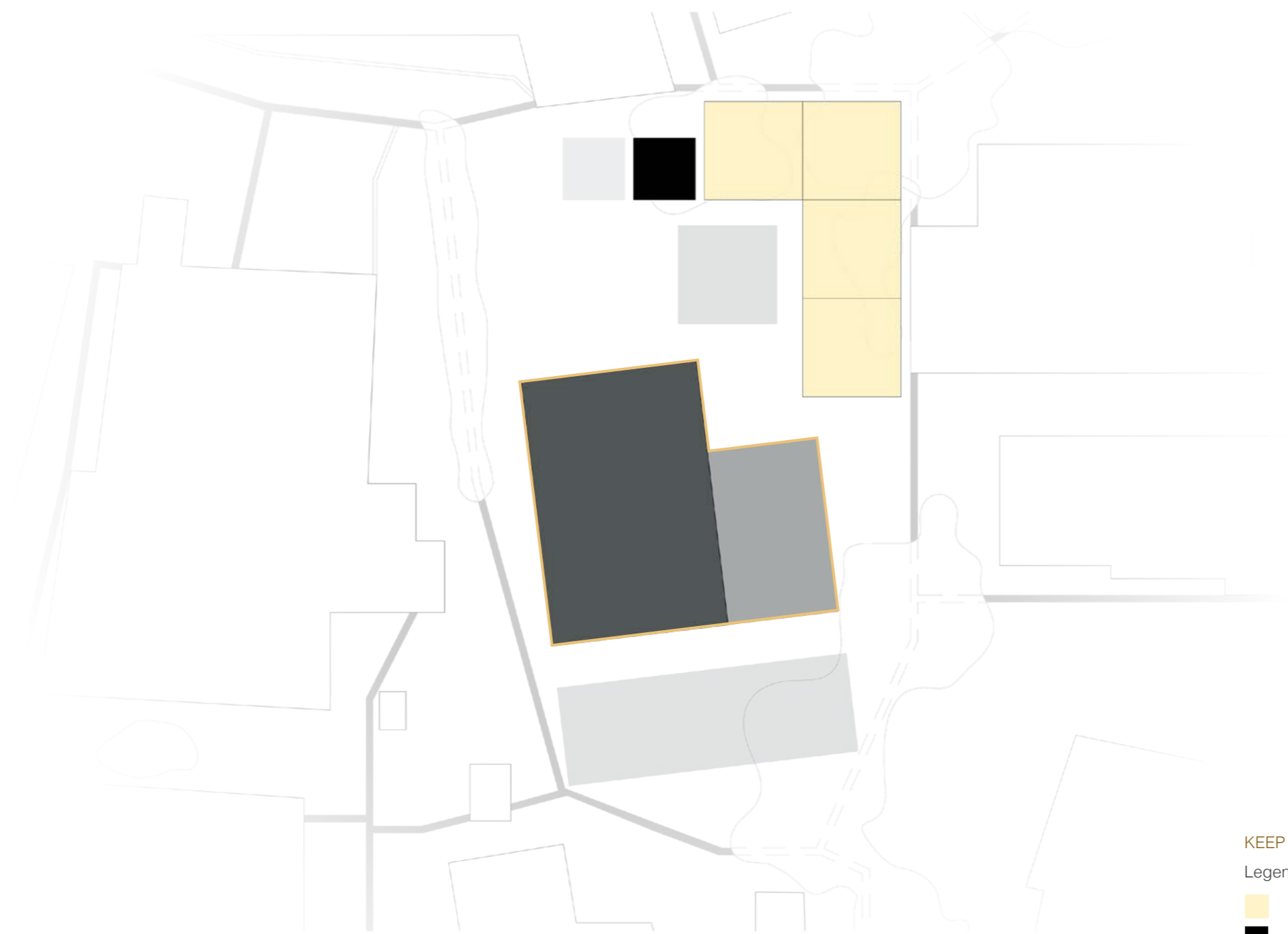







KEEP – CONCEPT TEAM PRODUCT

Legend

-  Workspace and Storage
-  Dogs
-  Parents – Kitchen/Living/Sleeping
-  Daughter – Living/Sleeping
-  Toilet
-  Garden
-  Existing Structure

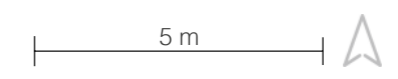

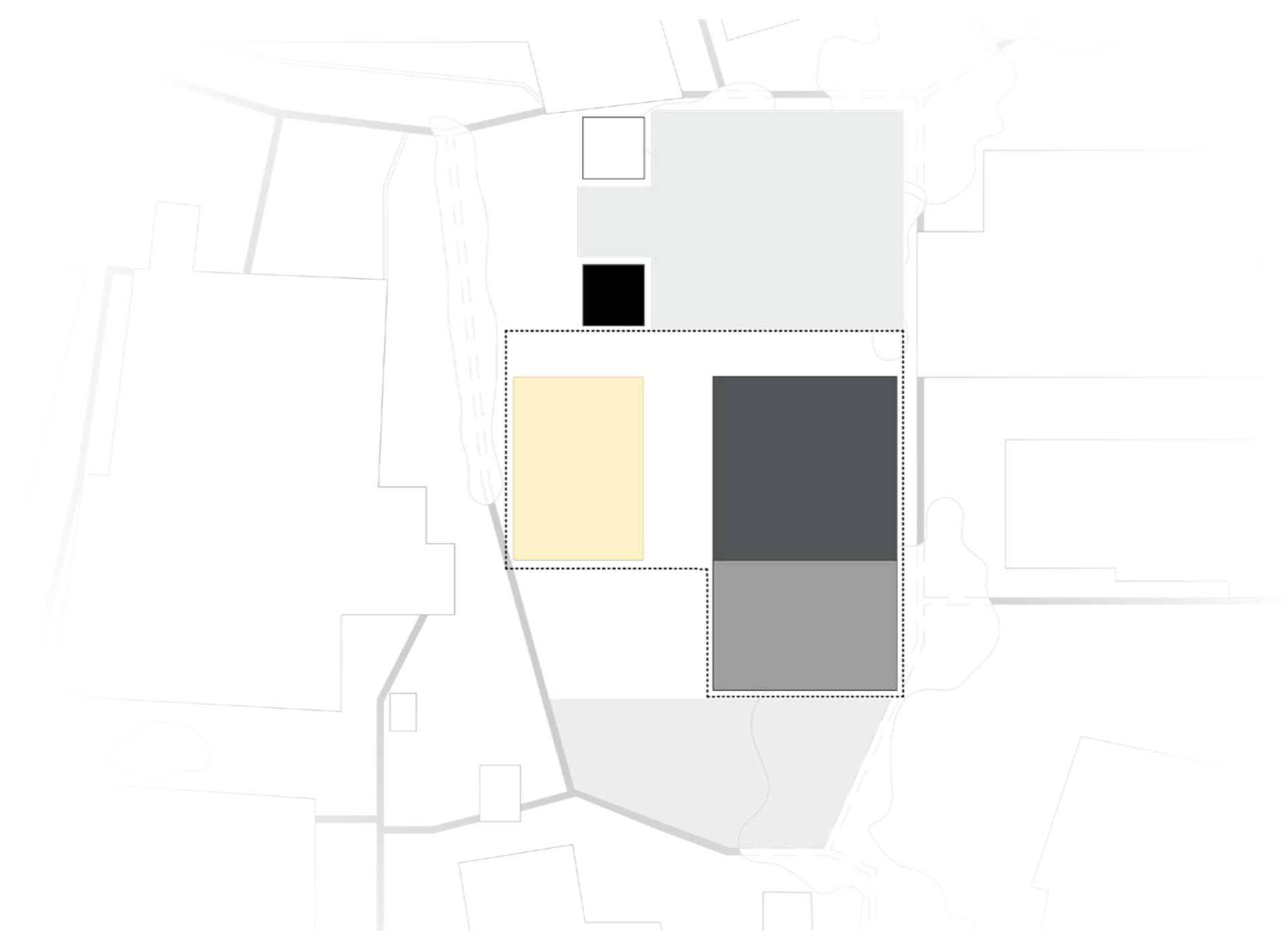

REFRAME – CONCEPT TEAM ARCHITECTURE

Legend

- Workspace and Storage
- Dogs
- Parents – Kitchen/Living/Sleeping
- Daughter – Living/Sleeping
- Toilet
- Garden
- Outline Roof

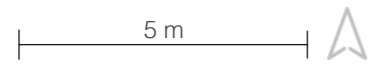



## ALENA

ARCHITECTURE

languages: German, English, French

skill set: Design skills - Digital Design: Archi + AutoCAD, SketchUP, Adobe Programmes  
analytical problem-solving skills  
team-building  
organisation, time management and coordination  
maths and science  
arts and crafts

spirit animal: Persian cat

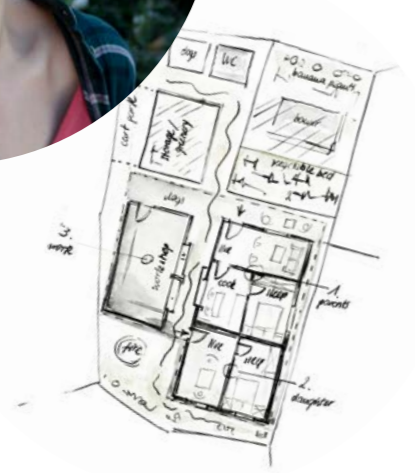

## KELSEY

HUMAN SETTLEMENT DEVELOPMENT

languages: English

skill set: planning and developing cities and towns with sound infrastructure that are economically viable, socially acceptable and environmentally friendly  
sustainable human settlements  
improving living conditions  
interior design

spirit animal: otter



## UTA

CIVIL ENGINEERING

languages: German, English, French

skill set: structural principles  
building construction  
mathematics, physics and chemistry  
structures of building material  
stability

spirit animal: zebra



## SBU

ELECTRICAL ENGINEERING

languages: isiXhosa, English

skill set: electrical wiring (low voltage)  
installation of PV Panels  
wood work, metal work  
team player and stress resistant  
communication skills

spirit animal: eagle

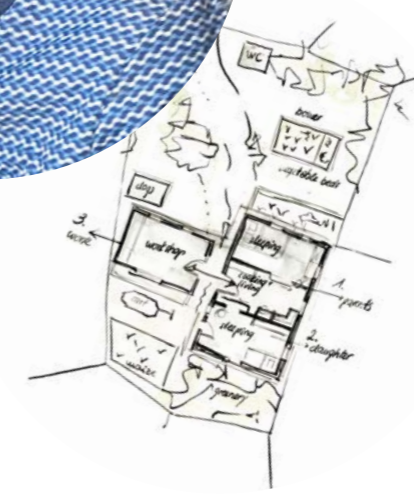



# CONCEPT

## V.IV THE STRONGEST POINTS COMBINED

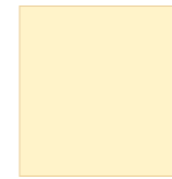

### WORKING

Separate workshop and storage area for recyclable materials and repair jobs



### LIVING I

Living spaces separated from each other to ensure privacy



### LIVING II

Daughter's living space is independent from the parents' part of the house

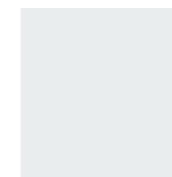

### GARDENING

Space for growing vegetables and maize as an additional source of food



### TOILET

Moved away from the front to create a more welcoming entrance and shorten the distance from house to toilet



### DOGS

Kept in front to safe-guard the property, the workshop and the stored materials







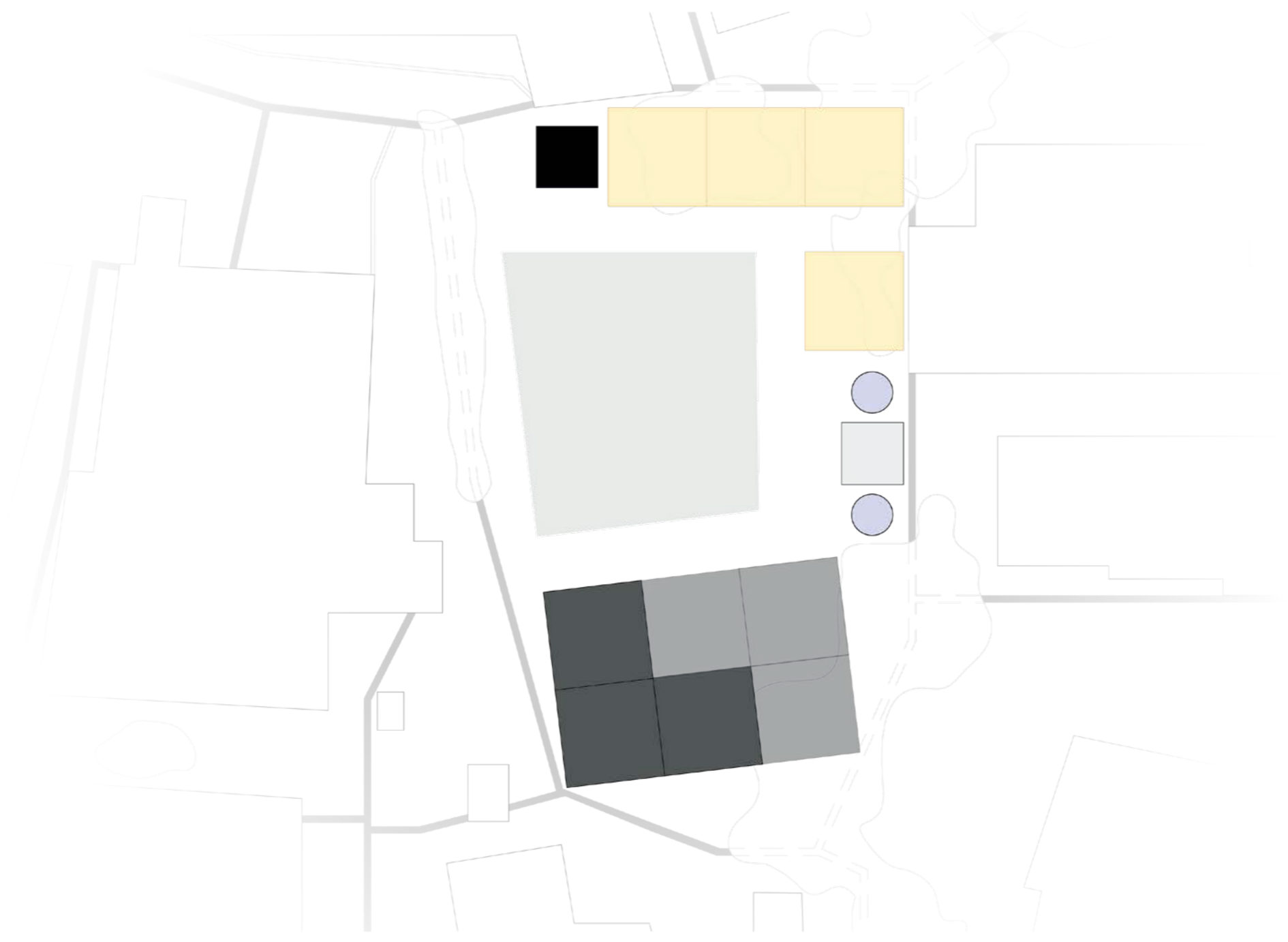

### WATER

Offer water for gardening to ensure food supply even during dry periods



FINAL LAYOUT AND DISTRIBUTION OF FUNCTIONS

Legend

-  Workspace and Storage
-  Dogs
-  Parents – Kitchen/Living/Sleeping
-  Daughter – Living/Sleeping
-  Toilet
-  Garden
-  Rain Water Tank

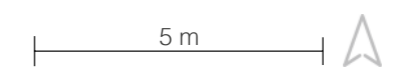

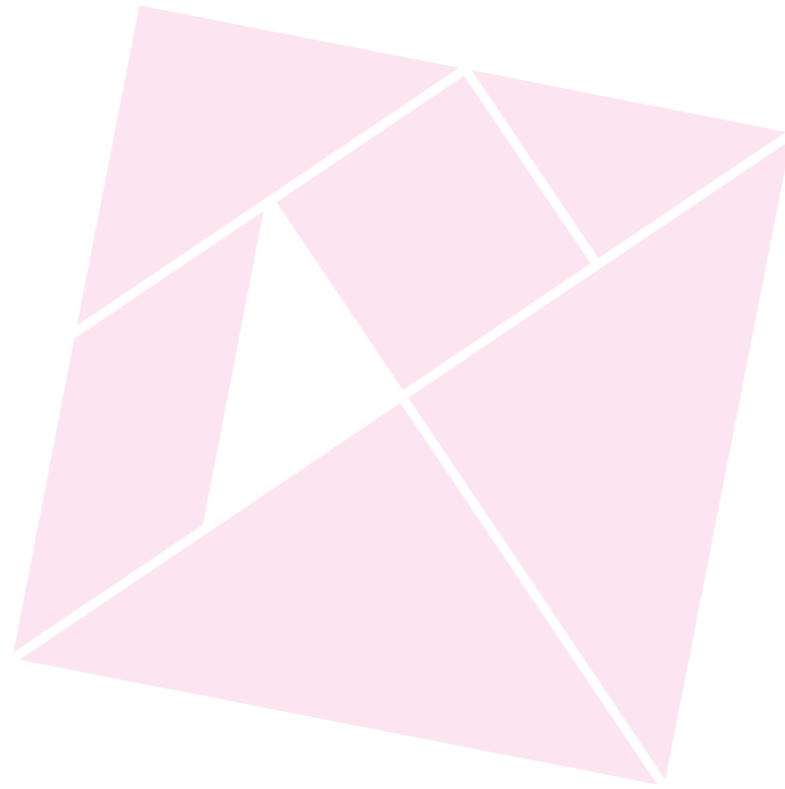

# DESIGN

FLOOR PLANS – DETAIL SOLUTIONS – FINAL DESIGN



# DESIGN

## VI.I INTRODUCTION AND IMPRESSIONS

*After three intense days of gathering, comparing and discussing we agreed on a final layout. The next step was to further develop the idea by means of 3D-models, technical drawings, floor plans, sections and elevations while planning the actual implementation process side by side.*



View across the property towards the entrance



Small blocks represent toilet and rain water tanks



Main house on the right, workshop on the left





Bird's view onto final model



# DESIGN

## BUILDING IN PHASES

Khusta's property does not offer a lot of space, neither for installing new structures nor for people working there. Furthermore family Moko cannot move during the construction work as Khusta needs to do his work to make a living. Therefore the building process needs to be carefully staged in order to ensure that family Moko can continue their everyday life while at the same time the work on site can move forward quickly.

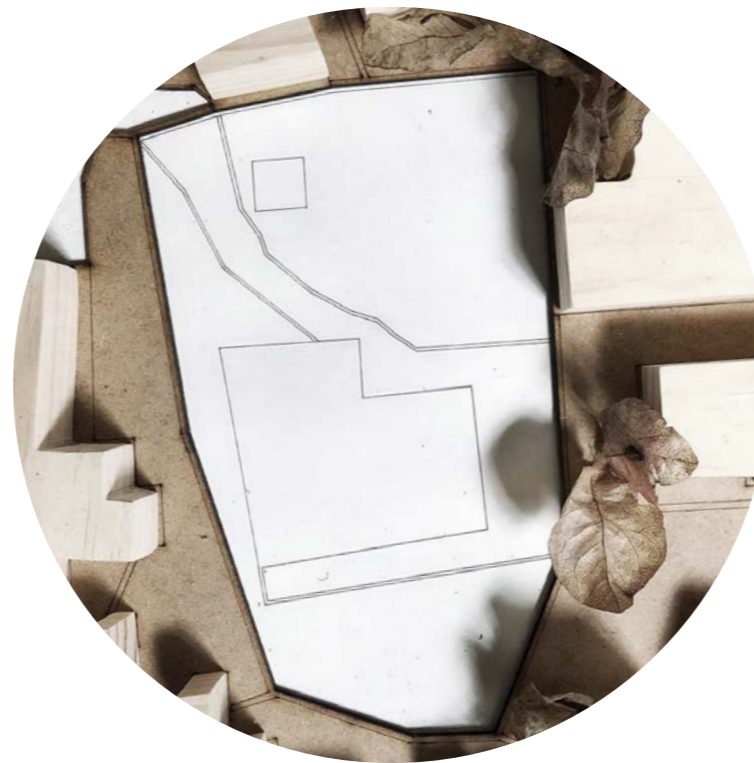

### STAGE 0

Current site plan: main house, toilet block, foot paths, garden area



### STAGE 1

Existing structure stays  
Implementation of workshop, storage, new toilet block and rainwater tanks





## STAGE 2

Existing structure stays  
New extension of the main  
house is built in the back  
(independent structure)  
Family moves into this structure



## STAGE 3

Extension becomes part of the  
newly built living space  
Old structure is slowly taken  
down (some parts and pieces to  
be kept for memory)



## STAGE 4

Old structure is removed, the  
family is now living in the newly  
built structure  
Garden set up in the front yard  
Workshop is running  
Possible business development  
in future

# DESIGN

## VI.III SITE PLAN

### PROJECT

The three-year project starts with the implementation of a workshop and storage building on the property of Khululekile Moko. Therefore a team from Germany arrives in February 2020 to finalise the design and build the structure. During the semester they took part in an elective module featuring the preparation for three intense weeks in South Africa.

### IMPLEMENTATION

The three weeks will consist of finalising the technical and construction drawings, preparation of building materials, pre-fabrication of building components and modules, as well as of the site preparation and building process on Khusta's property in Walmer Township.

### GOAL 2020

The goal of the 2020 Joint Action Project is to implement a structure that can be used for sorting and storing recycling material and for repair jobs by the beneficiary. While the outer basic structure ought to be finished by the end of february, interior furnishings are optional due to time constraints.





# DESIGN

## VI.IV DRAWINGS FOR EXECUTION



Analogue and digital work side by side



A 3D-model as the basis for the construction drawings



Team work in the planning process

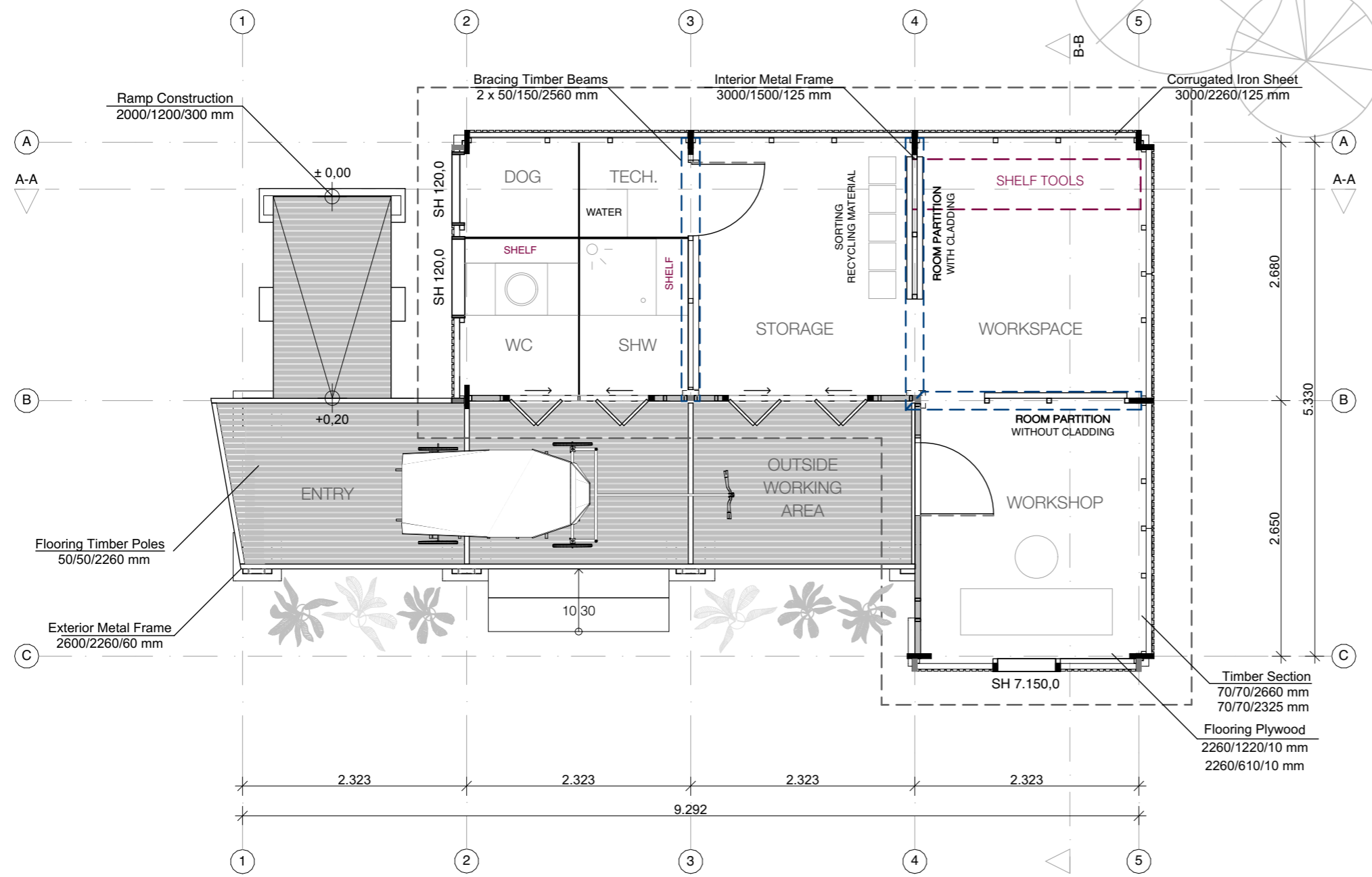

FLOOR PLAN

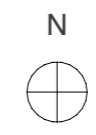
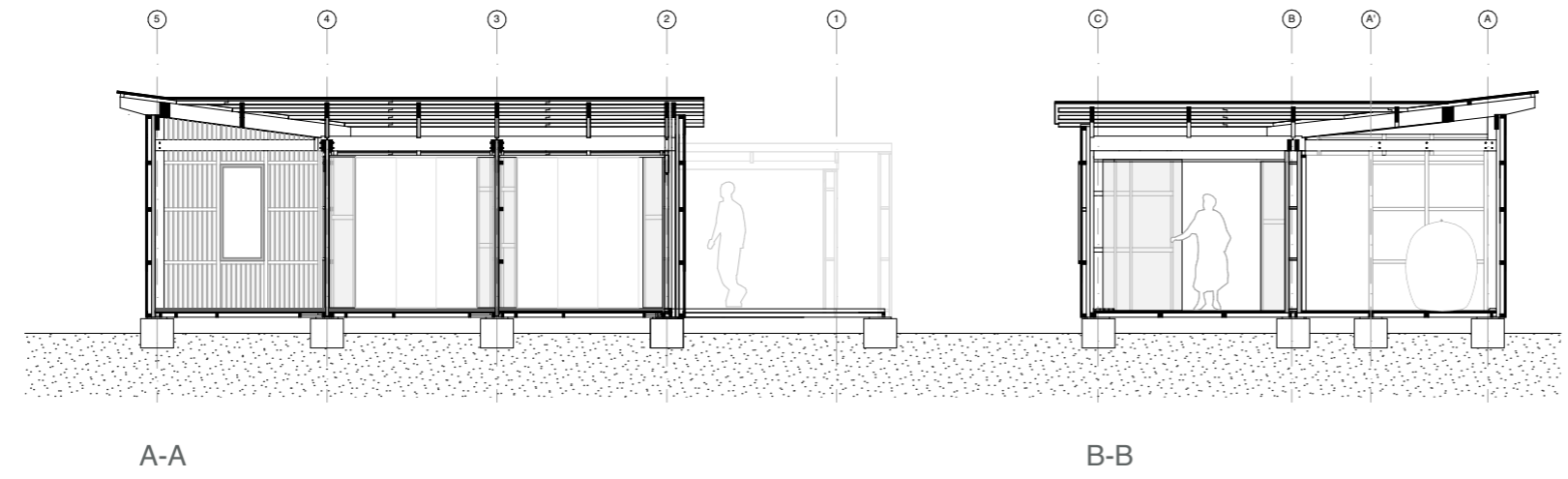

SECTIONS

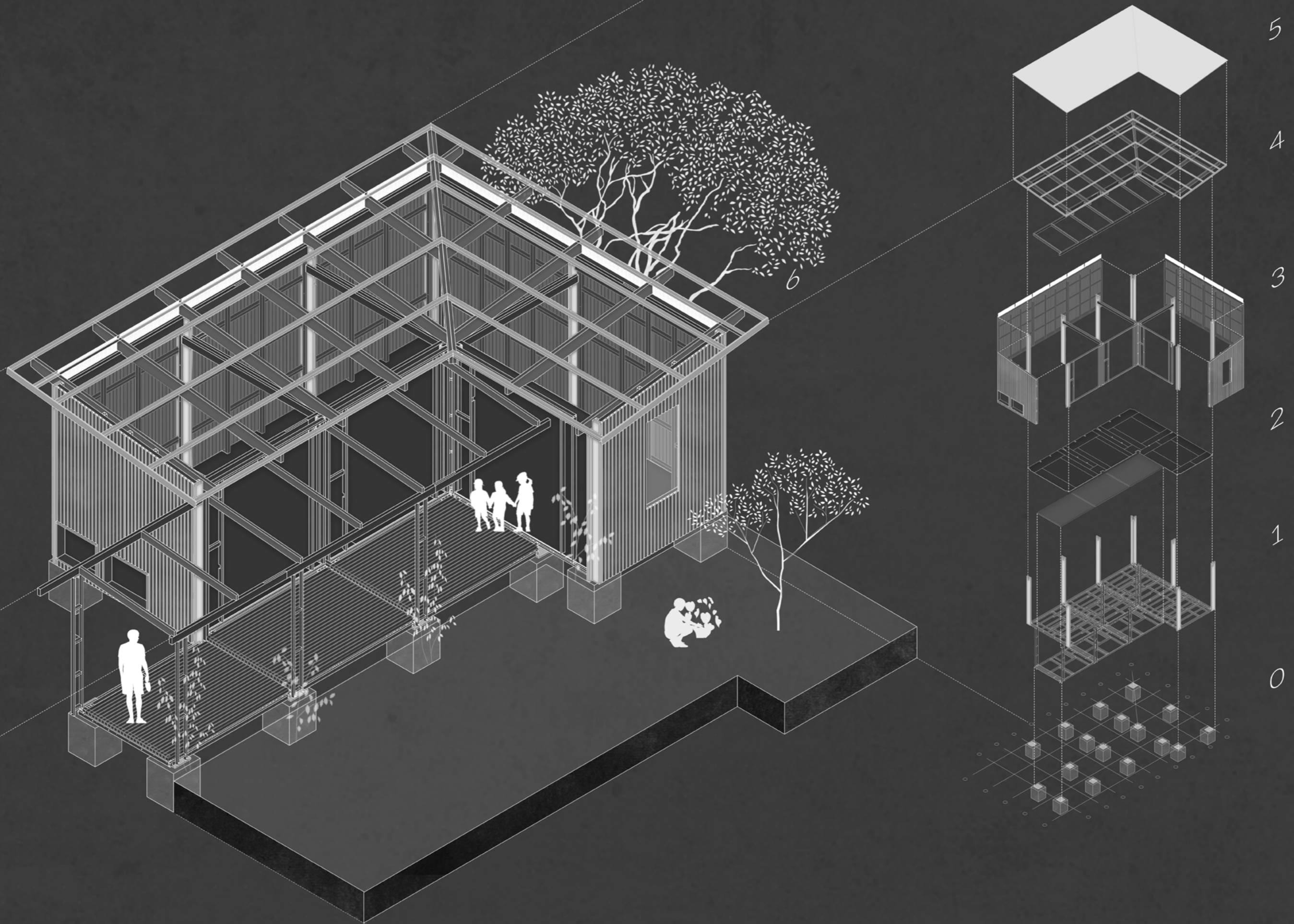

Isometry and exploded assembly



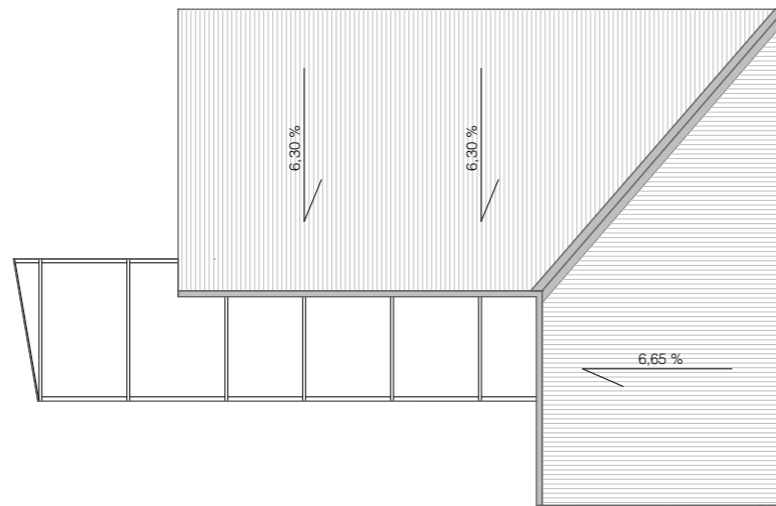

## ROOF THE SHEETING

The workshop will be roofed with corrugated iron sheets that are going to be purchased from a local supplier. The roofing consists of a reliable, weather-proof material in order to shield the stored material from environmental influences. Therefore we will use new material to ensure sustainability and persistence throughout the coming years.

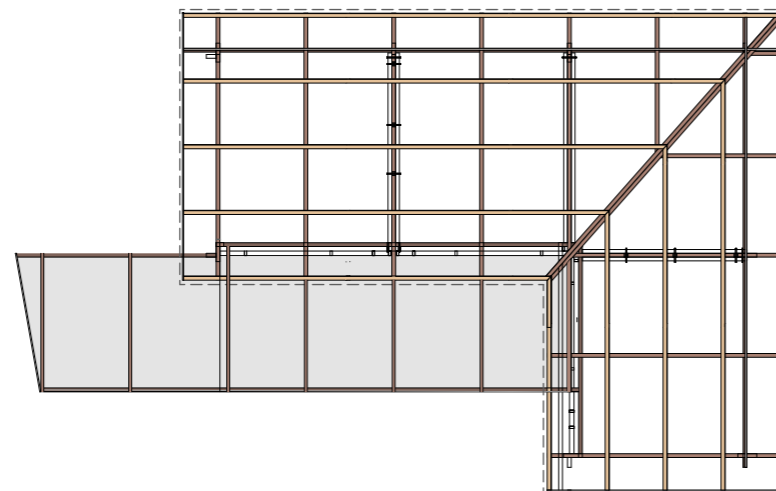

## ROOF THE SUBSTRUCTURE

The corrugated iron sheets will be supported by battens, rafters and purlins as well as columns made out of timber poles. The poles are going to be planed, trimmed and laminated creating the required dimensions and strength of the primary structure.

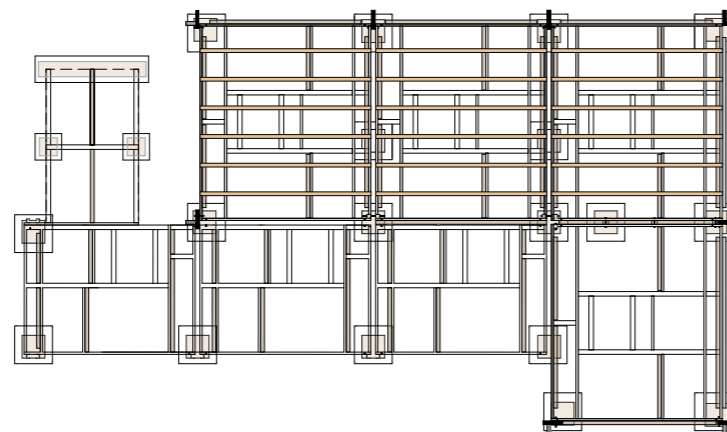

## FLOOR THE BASIC STRUCTURE

The base for the structure will be assembled of metal frames that are complemented by timber poles, forming the jointing components of the later floor. The frames will be grinded and treated with rust-proofing in order to ensure persistence.

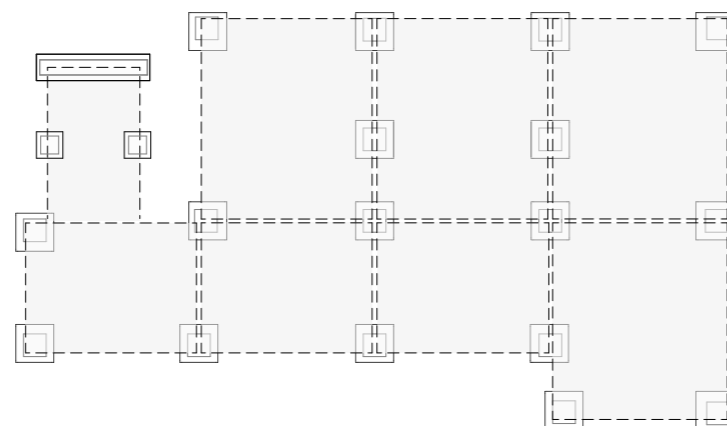

## FOUNDATION THE BASE

We decided to use point foundations in order to avoid extensive digging and high amounts of concrete. Responding to the difficult soil conditions on the property, the foundations needed to have a size of 500/500/500 mm.

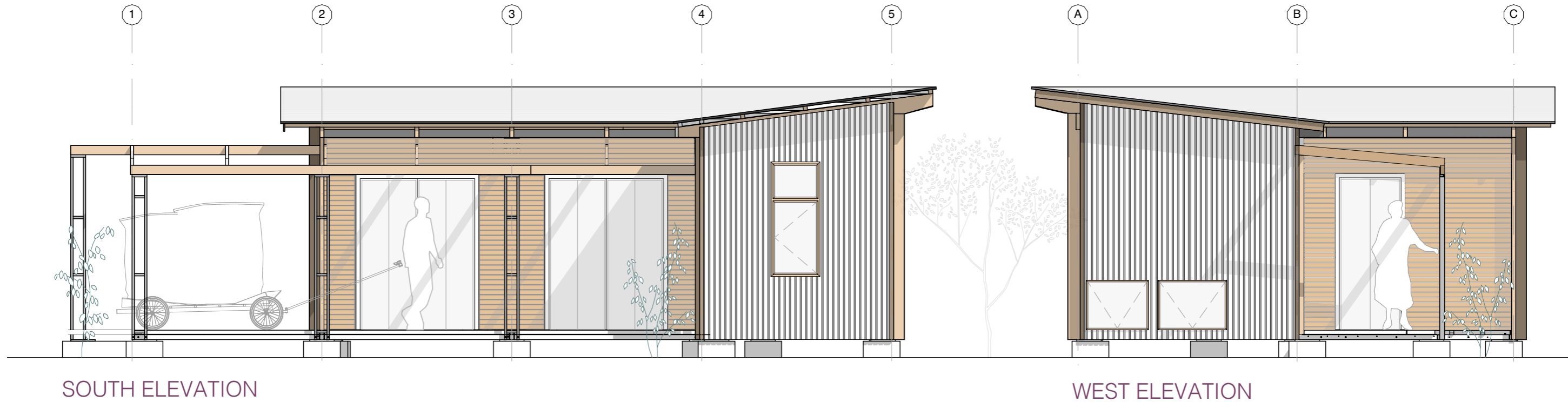

SOUTH ELEVATION

WEST ELEVATION

## DETAILS

### JOINTS AND JUNCTIONS

For the building process, the drawings of joints proved to be of high importance. The top line shows how the parts of the roof structure like rafters, purlins and binders are to be combined so as to ensure a stable structure. They also give an orientation of how the laminated pieces need to be trimmed in order to match their counterpart. At same time it illustrates the way the wall elements are going to be implemented.

The bottom line depicts the embedment of the timber and metal columns into the foundation and the attachment to the metal frames of the floor substructure. Furthermore it gives an idea of how the metal frames are going to be prepared for being able to carry the actual floor.

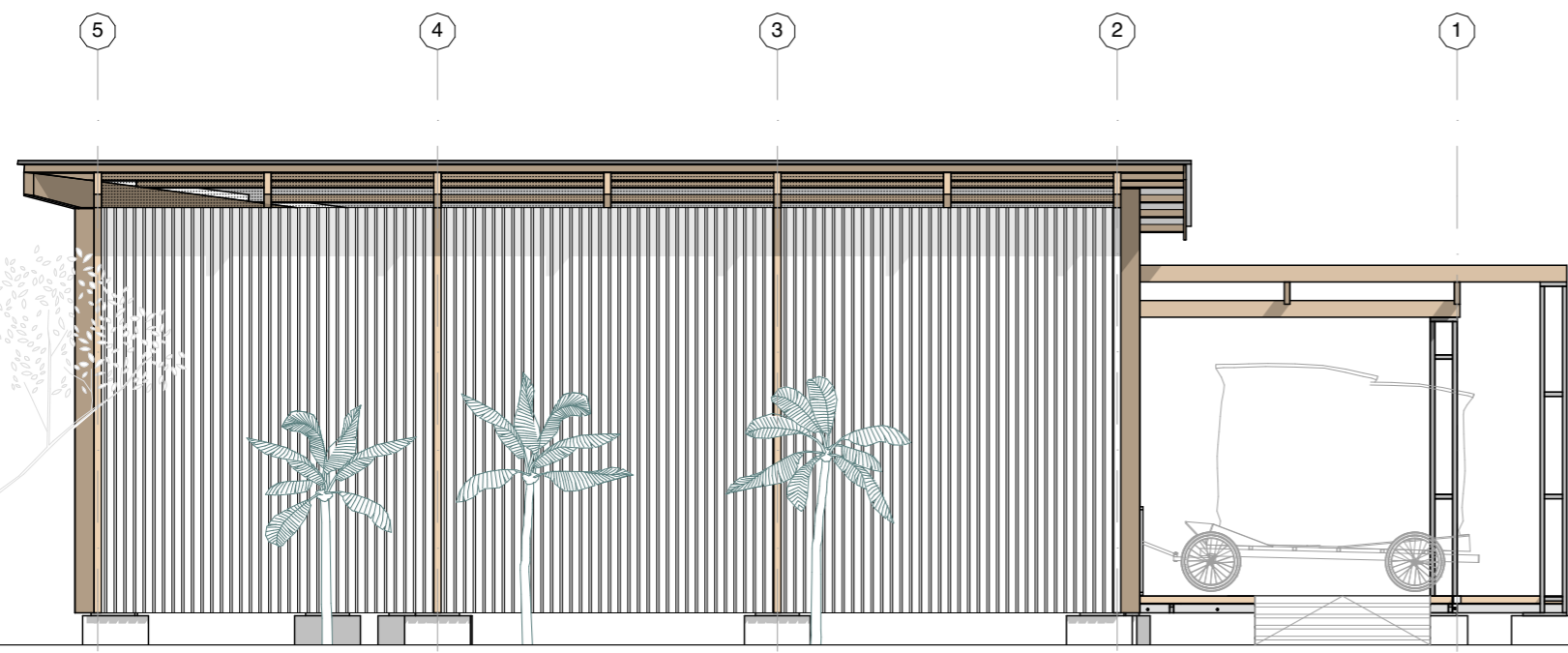

NORTH ELEVATION

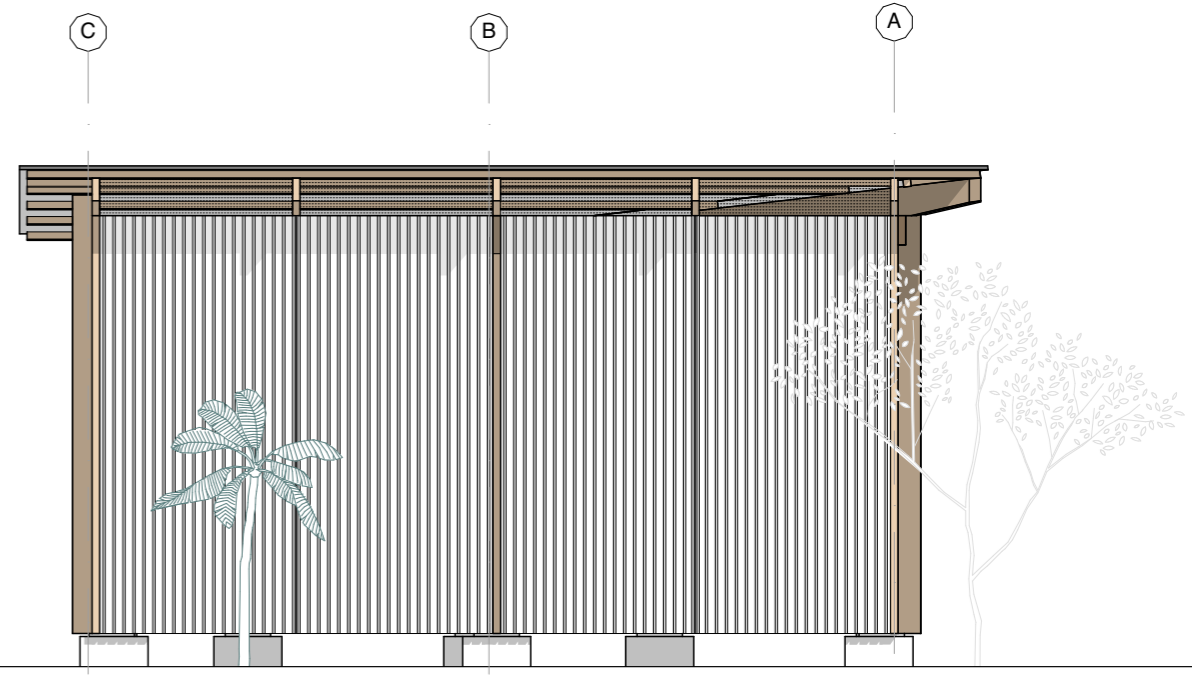

EAST ELEVATION

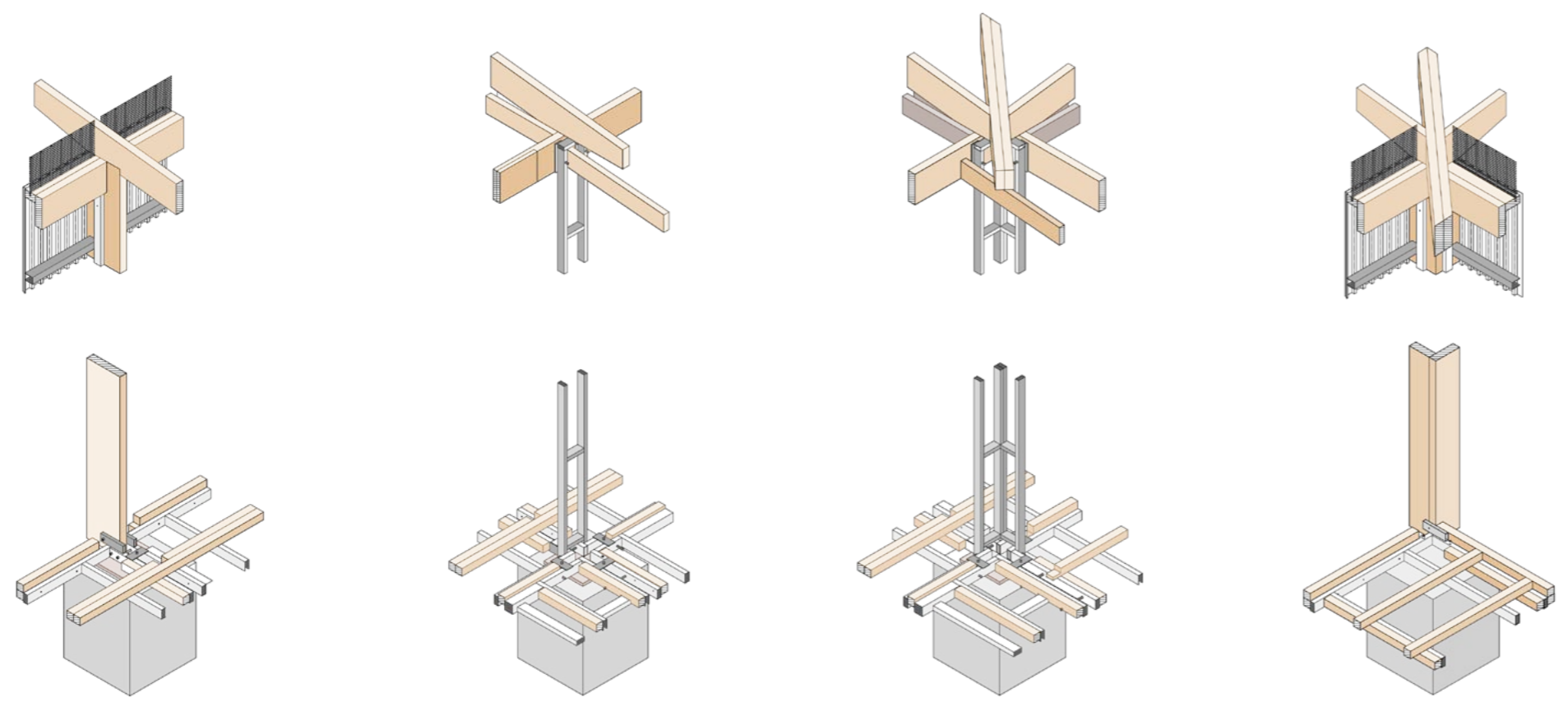

Base Point and Top Interface Gridline 3-A

Base Point and Top Interface Gridline 3-B

Base Point and Top Interface Gridline 4-B

Base Point and Top Interface Gridline 5-A



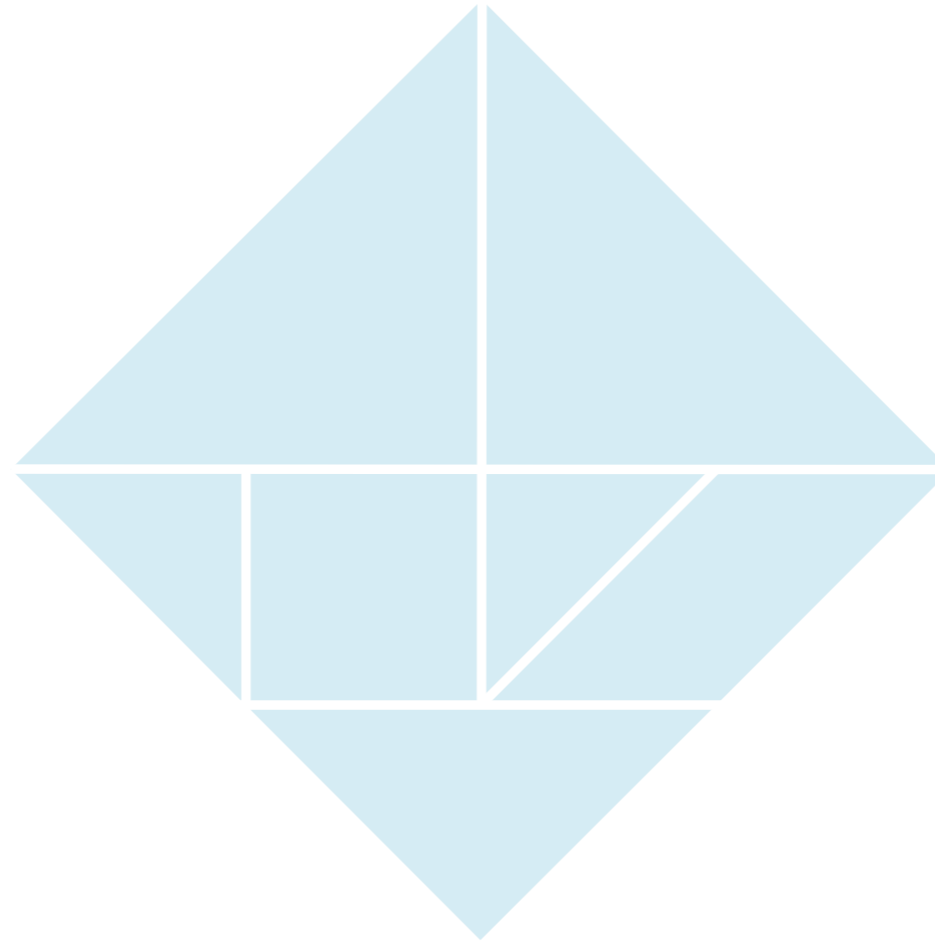

# IMPLEMENTATION

SITE WORKS – BUILDING PROCESS – RESULTS

# IMPLEMENTATION

## VII.I INTRODUCTION AND IMPRESSIONS

*February 2020 was under the banner of site work, of circular saws, drills and grinders, of sweat, dirt and concrete. Building a house in three weeks is a challenge. A challenge that was happily accepted by an international, cross-disciplinary and extremely motivated team.*



Timber production



Preparing for the concrete delivery



Final touches





The «Makerspace»  
living up to its name



# IMPLEMENTATION

## VII.II THE CONSTRUCTION TEAM



ALENA



CARSTEN



CLEMENS



ENNE



EVA



FRAUKE



HLWATI



JANA



JANN



KELSEY



LEA



LELETHU





LENA



LIKHONA



MARA



MAX



MILENA



MORITZ



MORTEN



PIA



SBU



SILKE



SNE



SOPHIE



UTA



VICTORIA



WOLFGANG

# IMPLEMENTATION

## VII.III TASKS AND PRE-FABRICATION



## FOUNDATIONS

### FORMWORK AND REINFORCEMENT

Usage:	Base of the structure
Material:	Structural plywood, screws, reinforcing steel, binding wire Table saw, (cordless) drill, spanner, muscle power
Tasks:	Cutting the plywood and assembling the formwork Bending the reinforcement Assembling the reinforcement cage
Challenges:	Bending 12-mm steel





## METAL FRAMES

### PREPARATION OF THE SUBSTRUCTURE

Usage:	Primary structure Base for the flooring
Material:	Metal frames, primary and rust-protective paint, wooden poles, screws, machine oil Brushes, (cordless) drills, drill bits, power, stamina, nerves of steel
Tasks:	Grinding Application of primer and rust-proofing paint Marking and pre-drilling of holes Applying the wooden substructure for the flooring
Challenges:	Differences between frames Deviations from drawings Blunt drilling bits



## WOOD WORK

### LAMINATING WITHOUT A BREAK

Usage:	Primary structure Structural support of the roof structure Roof structure
Material:	Wooden poles (50x70), wood glue, linseed oil Brushes, spreader, clamps, chop saw, planer, speed, patience
Tasks:	Planing and trimming (45-degree-angle) Laminating and clamping 2 – 4 poles together Waiting during drying process Planing, trimming and cutting them according to drawings Chamfering Painting with linseed oil for weather protection Pre-drilling and pre-assembling
Challenges:	Glue drying faster than expected Warped poles Shortage of clamps



## WALL ELEMENTS

WHERE THE SPARKS FLY

Usage:	Façade
Material:	Sheeted metal frames, metal frames, primary and rust-proofing paint, wooden poles, screws, machine oil (cordless) drills, drill bits, brushes, power
Tasks:	Grinding Application of primer and rust-proofing paint Marking and pre-drilling of holes Applying the timber substructure for the façade Cutting the elements of the façade Cutting and applying the chipboard for the cladding Cutting, planing, chamfering and applying the door frames
Challenges:	Applying additional metal profiles Wrong measurements Adjustment of the chipboards



## FLOOR

POLE AFTER POLE AFTER POLE ...

Usage:	Floor covering inside and outside
Material:	Timber poles (50x50), plywood, screws, linseed oil Circular saw, planer, brushes, sense of detail, perfectionism
Tasks:	Planing, chamfering and painting the timber poles for the veranda Measuring and cutting the plywood boards for the inside floor Adjusting
Challenges:	Warped poles Shortage of poles



## OPENINGS

### (UN)FITTING FRAMES

Usage:	Openings, entrance and natural lighting
Material:	Timber poles, wood glue, linseed oil, polycarbonate boards Brushes, chop saw, planer, stamina, sense of proportion
Tasks:	Planing and trimming the poles Cutting, grinding, sanding and inserting polycarbonate panes Glueing frames Chamfering Painting with linseed oil for weather protection
Challenges:	Lack of sense of proportion Swap of wall elements High transparency of panes



## WOODEN FAÇADE

### DESIGN AND DESASTER IN ONE

Usage:	Covering the Southern and Western façades of the building Weather protection Appearance
Material:	Timber poles (70x70), screws, linseed oil Table saw, planer, chop saw, brushes, mathematical talent, patience, stamina
Tasks:	Calculating quantities and most efficient cuttings Splitting, planing, chamfering and trimming the poles Painting
Challenges:	Wood shortage Broken saw



# IMPLEMENTATION

## VII.IV THE ASSEMBLY



### CLEARING

Khusta's property is repleted with plants, stored material, bowers and small storage facilities. In order to set the foundation we remove and transplant everything from the front of the plot.



### FOUNDATION

Digging holes, squaring the formwork and fighting with roots and rubbish piles define the following days. The concrete is delivered at the end of the second week.



### FLOOR

The metal frames as the substructure for the floor are attached directly to the foundations by rooting them in the dried concrete by means of special concrete anchors.



### COLUMNS

The most important tool during the erection of the poles are the levels. The columns need to stand perfectly straight in order to allow us to insert the wall elements in the next step.





## WALLS

The wall elements are tilted between the columns and then slid in a gap at the bottom. Screws hold them in place and close small gaps between columns and wall.



## FAÇADE

After the supporting structure is set, the attachment of the façade elements begins. «Stubborn» wood, power cuts and changes of plans complicate the process.

## ROOF

Rafters and purlins are attached in the next step followed by battens. The structure is covered with specifically adjusted, corrugated sheets responding to the surrounding.



## INTERIORS AND DOORS

The two separate rooms are serving as sanitary facility and storage. Folding and normal doors, two hatches, windows, and toilet bench are installed. The first picture is hung up by Khusta.

## VERANDA

The floor of the veranda made out of timber poles requires lots of patience especially after realising that the timber substructure does not match the positions of the poles.



## DETAILS

Final touches to the structure: A pulley is installed to make it easier for Khusta to lift heavy stuff; A sign saying «Khusta's Re-Usables» shows the proud ownership.

## PERGOLA

The structure in front of the workshop consists of rafters and purlins screwed together with spax screws. The pergola serves as a climbing support for grapes.



## GARDEN

Apart from the building we also set up a new garden. Banana plants, grapes and a lemon tree are just a few of the new inhabitants. A rain water tank secures the water supply.



# IMPLEMENTATION

## VII.V THE FINAL STRUCTURE



Exploring the new veranda



Khusta showing friends around



Lady already feels at home





KHUSTA  
RE-USABLE



The final structure  
of the workshop.





Khusta and Patricia in front of the main door



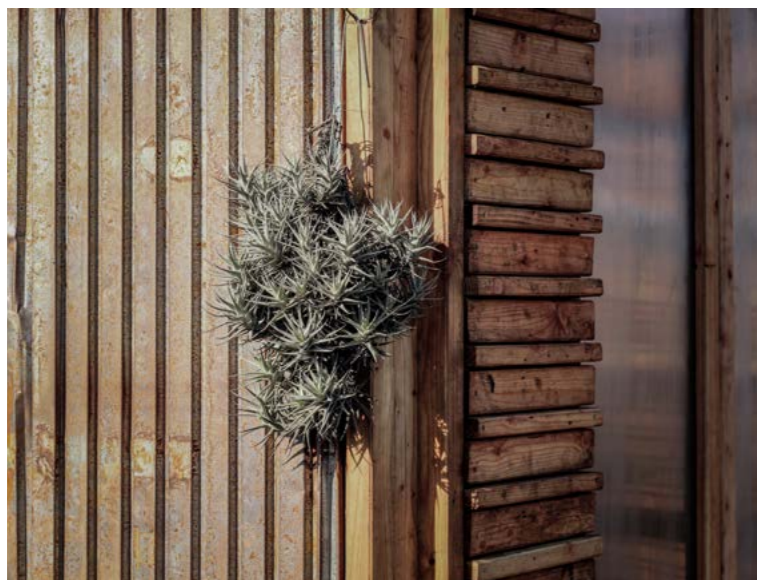

Personal touches



Rain water collection on side



Detail of the interior wall



# IMPLEMENTATION

## VII.VI POSTSCRIPT

Dear Reader,

three weeks is not a lot of time to construct a building.

Especially not when you are facing new challenges day by day, ranging from missing screws over power cuts to uncertainties whether our plans are implementable at all, after circumstances turned upside down. So instead of jumping straight into physical work on site when the Wismar-team arrived we needed to do a bit of re-planning. At the same time preparations started at Makerspace: dismantling palettes, refurbishing the donated material and starting the prefabrication of building elements. Due to final clarification regarding the work on Khusta's property, we only started clearing the site in the second week and finished the foundations at the end. Therefore, there was only one week left to assemble the whole structure.

But our days did not only consist of stressful and energy-sapping work at Makerspace and on site. They were also filled with lots of silly moments and laughter. The whole time was composed of ups and downs, of sunshine and pouring rain, of things that worked perfectly at the first attempt and things that required days and nerves alike. But first and foremost, these three weeks were shaped by the incredible teamwork and personal effort of each and every team member. Up to the very last moment, drills and saws were in action. The last screw was put in only minutes before the picture on the right was taken.

Everything is in place and the workshop is ready to be used. However, the building only serves as a shell that is going to be brought to life by Khusta and his family themselves, according to their personal needs and preferences. Hopefully, our intention to support his small business in a truly sustainable way will thus come to fulfillment.

These three weeks can be seen exemplary for the whole time we, the pioneers, spent together. Three weeks are symbolising our whole semester: with all the craziness, challenges and joy, with strangers becoming friends and pioneers turning into a family standing together.

This whole project showed us and everyone partaking in it, virtually or physically, as a supporter, friend or family member, what can be achieved when people work together. It shows what can happen, when a bunch of young people from different backgrounds combine their knowledge, skills and power towards a collective goal. It shows, that we can indeed make a difference in the world, by working together and by supporting one individuum who is making a difference to himself and others.

We, the first pioneers, joined this JAP and filled the gap. But more than that, we also created the bond between countries, universities and most importantly between people. We learned from each other, we exchanged skills, worldviews and music. Our South African friends showed and shared their home with us. Now we are looking forward to doing the same when they are coming to Germany. The planning process already started.

Let us continue the story.

*The Pioneers*





**KHUSTA'S  
RE-USABLES**

The construction team with Khusta in the centre



# APPENDIX

## A. TEAM MEMBERS AND SUPPORTERS

### PARTICIPANTS

Carsten Arndt (Architecture)  
Mara Biebow (Communication Design and Media)  
Kelsey Bruce (Human Settlements)  
Lelethu Buso (Development Studies)  
Sibusiso Dyantyi (Electrical Engineering)  
Alena Engel (Architecture)  
Morten Fuchs (Architecture)  
Maximilian Gedamke (Architecture)  
Lena Güntsche (Architecture)  
Clemens Jopp (Architecture)  
Victoria Sophie Langer (Architecture)  
Jann Lübbers (Architecture)  
Jana Meier (Architecture)

Sophie Meßmer (Architecture)  
Sinethemba Mncono (Electrical Engineering)  
Pia Mohring (Architecture)  
Milena Louisa Müller (Architecture)  
Frauke Nessler (Architecture)  
Moritz Niebler (Architecture)  
Likhona Nqunga (Development Studies)  
Enne Püschel (Architecture)  
Dumisani Qwabe (Human Settlements)  
Uta Scheibe (Civil Engineering)  
Hlwati Siggibo (Electrical Engineering)  
Lea Strauss (Communication Design and Media)  
Eva Wachauf (Architecture)

### COORDINATORS AND SUPERVISORS

Prof. Janet Cherry (Development Studies, Nelson Mandela University, Port Elizabeth)  
Wolfgang Dörk (Head of workshop facilities at Wismar University of Applied Science)  
Prof. Silke Flaßnöcker (Architecture, Wismar University of Applied Science)  
Kevin Kimwelle (Architect, Ph.D. Candidate at Nelson Mandela University, Port Elizabeth)  
Prof. Sijekula Mbanga (Human Settlements, Nelson Mandela University, Port Elizabeth)



# APPENDIX

## B. SOURCES AND REFERENCES

### ACADEMIC RESEARCH

EDITORS OF RNEWS: Nelson Mandela Bay Municipality opens revamped Fountain Road in Walmer (press release), September 2017, URL: <https://www.rnews.co.za/article/16278/nelson-mandela-bay-municipality-opens-revamped-fountain-road-in-walmer> (access: 30.10.2019).  
IMIZI HOUSING Homepage, Walmer Links, 2003. URL: <http://www.imizi.co.za>  
MASIFUNDE LEARNER DEVELOPMENT: umhlali GQEBERA NEWS, edition 1, January 2016.  
JASON HENRY TAGG: Providing Adequate Housing in South Africa in the twentieth and twenty first Century, October 2012. (access via: <https://pdfs.semanticscholar.org/a5ca/51a6d5c19b8ab848502ac8195ec56b68a1dd.pdf>)  
KATE TISSINGTON: A Resource Guide to Housing in South Africa 1994-2010. Feb 2011. (access via: [http://www.urbanlandmark.org.za/downloads/SERI\\_Housing\\_Resource\\_Guide\\_Feb11.pdf](http://www.urbanlandmark.org.za/downloads/SERI_Housing_Resource_Guide_Feb11.pdf))

### MEMORY MINUTES

JANET CHERRY, PROF. (project coordinator and SLP facilitator): Information about history of South Africa and Walmer Township, Memory minutes of talks and lectures during October, November and December 2019.  
KEVIN KIMWELLE (project coordinator and architect): Information about Walmer Township, Memory minutes of talks during October and November 2019.  
KHULULEKILE «KHUSTA» MOKO (beneficial and Walmer Township resident): Information about Walmer Township and Area G West, Memory minutes of talks during visits in October, November and December 2019.

### OTHER

All information on the maps from:  
<https://www.openstreetmap.org> (various dates) and <https://www.google.com/maps> (various dates)  
All numbers and statistics from Stats SA, Census 2011:  
<http://superweb.statssa.gov.za/webapi/jsf/dataCatalogueExplorer.xhtml> (29.10.2019)  
All information about history from Softschools Timeline:  
[http://www.softschools.com/timelines/apartheid\\_timeline/44/](http://www.softschools.com/timelines/apartheid_timeline/44/) (29.10.2019)



# APPENDIX

## C. PARTNERS AND SPONSORS



IN COOPERATION WITH:

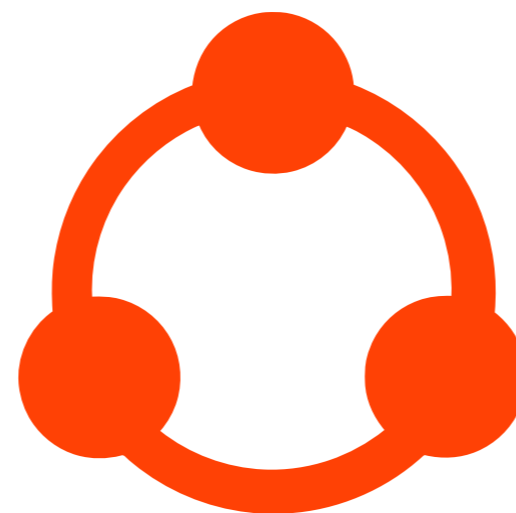

**PORT ELIZABETH  
TVET COLLEGE**



SPONSORED BY

**DAAD**

Deutscher Akademischer Austauschdienst  
German Academic Exchange Service

By means of the Federal Ministry for Economic Cooperation and Development (Bundesministerium für wirtschaftliche Zusammenarbeit und Entwicklung – BMZ)

Sto  Foundation

SPECIAL THANKS TO

Bettina und Heinz-Georg Ruffert  
Robert-Schmidt-Institute of Wismar University of Applied Science  
Förderkreis der Hochschule Wismar e.V.

THANKS TO

Jürgen Arndt	Oliver Hantke
Holger Betz	Inge Niebler
Margret Böthig	Noemi Patzschke
Marc Eichner	Henning Rasmuss
Ulf Gedamke	Sabine Schuldt
Knut Göppert	Steven Wilbreninck

And all other supporters from [www.betterplace.org](http://www.betterplace.org)



# APPENDIX

## D. CONTRIBUTORS

### EDITORS

Mara Biebow  
Alena Engel

### LAYOUT

Mara Biebow  
Alena Engel

### TEXT

Mara Biebow  
Alena Engel

### COPY EDITING

Mara Biebow  
Prof. Janet Cherry  
Alena Engel  
Prof. Silke Flaßnöcker

### PHOTOGRAPHY

Mara Biebow  
Lelethu Buso  
Alena Engel  
Frauke Nessler  
Uta Scheibe  
Lea Strauss

### DRAWINGS

Alena Engel  
Jana Meier

### MAP DESIGN

Alena Engel

### LOGO DESIGN

Mara Biebow

### TYPOGRAPHY

Helvetica Light  
Helvetica Regular

A production by Wismar University of Applied  
Science, Technology, Business and Design.  
For more information about the project, please visit:  
[fg.hs-wismar.de/joint-action-projects/news](http://fg.hs-wismar.de/joint-action-projects/news)

Check out the video:  
[A Workshop for Khusta](#)



2019/2020